



Audio Engineering Society Convention Paper

Presented at the 113th Convention
2002 October 5–8 Los Angeles, California, USA

This convention paper has been reproduced from the author's advance manuscript, without editing, corrections, or consideration by the Review Board. The AES takes no responsibility for the contents. Additional papers may be obtained by sending request and remittance to Audio Engineering Society, 60 East 42nd Street, New York, New York 10165-2520, USA; also see www.aes.org. All rights reserved. Reproduction of this paper, or any portion thereof, is not permitted without direct permission from the Journal of the Audio Engineering Society.

Implementation of Straight-Line and Flat-Panel Constant Beamwidth Transducer (CBT) Loudspeaker Arrays Using Signal Delays

D. B. (Don) Keele Jr.

¹Harman/Becker Automotive Systems, Martinsville, IN 46151, U.S.A
E-mail: DKeele@Harman.com

ABSTRACT

Conventional CBT arrays require a driver configuration that conforms to either a spherical-cap curved surface or a circular arc. CBT arrays can also be implemented in flat-panel or straight-line array configurations using signal delays and Legendre-function shading of the driver amplitudes. Conventional CBT arrays do not require any signal processing except for simple frequency-independent shifts in loudspeaker level. However, the signal processing for the delay-derived CBT configurations, although more complex, is still frequency independent. This is in contrast with traditional constant-beamwidth flat-panel and straight-line designs which require strongly frequency-dependent signal processing. Additionally, the power response roll-off of conventional CBT or delay-derived CBT arrays is one half the roll-off rate of competing designs, i.e., 3- or 6-dB/octave (line or flat) for the CBT array versus 6- or 12-dB/octave for the other designs. Delay-derived straight-line CBT arrays also provide superior horizontal off-axis response because they do not exhibit the $\pm 90^\circ$ right-left off-axis sound pressure buildup or bulge as compared to conventional circular-arc CBT arrays. In comparison to conventional CBT arrays, the two main disadvantages of delay-derived straight-line or flat-panel CBT arrays are 1) the more complicated processing required which includes multiple power amplifiers and delay elements, and 2) the widening of the polar response at extreme off-axis angles particularly for arrays that provide wide coverage with beamwidths greater than 60° . This paper illustrates its findings using numerical simulation and modeling.

0. INTRODUCTION

CBT array theory is based on un-classified military under-water transducer research done in the late 70s and early 80s [1, 2]. The research describes a curved-surface transducer in the form of a spherical cap with frequency-independent Legendre shading that provides wide-band extremely-constant beamwidth

and directivity behavior with virtually no side lobes. The theory was applied to loudspeaker arrays by Keele in 2000 [3] where he extended the concept to arrays based on toroidal curved surfaces and to circular-wedge (also called circular-arc) line arrays.

The single major disadvantage of conventional CBT designs is their requirement for curved-surface and circular-line configurations. This paper extends the CBT theory to flat-surface and straight-line arrays. This is accomplished by the use of signal delays that approximate the curved surfaces or lines with electrical processing. It is found that the approximation works best for relatively narrow-angle coverage patterns of roughly 60° or less because the delay-derived curvature approximation does not work as well at extreme off-axis angles. If wide coverage's are approximated, the delay-derived out-of-beam patterns are significantly wider than a true CBT implementation of the same coverage.

The flat-panel or straight-line delay-derived CBT array requires different signal delays to each transducer(s) of the array, in addition to the Legendre shading which tapers the drive level from maximum in the center of the array to zero at the outside edge. Although this processing is much more complex than that required for a true curved CBT array which only requires simple frequency-independent shifts in driver level to implement the Legendre shading, the required processing for the delay-derived CBT array is still frequency independent, which simplifies the processing considerably.

Conventional flat-panel or straight-line designs which use an array of equal-spaced transducers require complex frequency-dependent signal processing to maintain constant beamwidth behavior [4, 5]. The required processing maintains an effective radiating aperture that is a constant size with respect to the radiated wavelength, and thus generates constant beamwidth with frequency. For a line array, this processing effectively halves the number of transducers operating for each octave increase in frequency. This generates a 6-dB/octave roll-off in power response over the complete operating bandwidth of the line array.

Correspondingly, a conventionally-implemented equally-spaced flat-panel array reduces the number of operating transducers by one-fourth for each octave increase in frequency which results in a power roll-off of 12-dB/octave. This behavior is in contrast with either a conventional or delay-derived CBT array which exhibits a power roll-off of only 3-dB/octave for a line array and 6-dB/octave for a flat-panel array over their respective operating bandwidths. This lower roll-off rate is directly related to the fact that all the drivers in a CBT array are operating over the whole frequency range.

This paper uses numerical simulation and modeling to illustrate its points, and predicts radiation patterns using three-dimensional discrete arrays of point sources.

The following sections are organized as follows: Section 1 reviews the general theory of both conventional and delay-derived CBT designs, Section 2 describes the numerical simulator and typical output results, Section 3 compares the acoustic output of several conventional and delay-derived CBT line arrays of widely varying coverage angles, Section 4 illustrates a delay-derived CBT line array designed for flat off-axis response at all off-axis angles, Section 5 compares a conventional spherical circular-cap CBT with a delay-derived circular flat-panel CBT array designed for the same coverage, Section 6 concludes the paper. A series of three appendices appear at the end which contain a majority of the simulator results.

1. THEORY

1.1 Review: Conventional CBT Arrays

Quoting from Keele [3, Section 1]: "Rogers and Van Buren [1], and Buren et. al. [2] describe the theory and experiments of what they call broadband "constant beamwidth transducers" (CBT) for use as underwater projectors and receivers for sonar use. Here the transducer is in the form of a circular spherical cap of arbitrary half angle whose normal surface velocity (or pressure) is shaded with a Legendre function. The Legendre shading is independent of frequency. This transducer provides a broadband symmetrical directional coverage whose beam pattern and directivity is essentially independent of frequency over all frequencies above a certain cutoff frequency, and also change very little with distance from the source. The transducer can be designed to cover any arbitrary coverage angle with a constant beamwidth that extends over an operating bandwidth which is, in theory, virtually unlimited."

“Rogers and Van Buren [1] determined that if the radial velocity (or equivalently the surface pressure) on the surface of a rigid sphere of radius a conforms to

$$u(\theta) = \begin{cases} P_\nu(\cos\theta) & \text{for } \theta \leq \theta_0 \\ 0 & \text{for } \theta > \theta_0 \end{cases} \quad (1)$$

where

- $u(\theta)$ = radial velocity distribution
- θ = elevation angle in spherical coordinates,
($\theta = 0$ is center of circular spherical cap)
- θ_0 = half angle of spherical cap
- $P_\nu(x)$ = Legendre function of order ν ($\nu > 0$) of argument x ,

then an approximation to the farfield pressure pattern, above a cutoff frequency which depends on the size of the sphere and the wavelength, will be

$$p(\theta) \approx \begin{cases} P_\nu(\cos\theta) & \text{for } \theta \leq \theta_0 \\ 0 & \text{for } \theta > \theta_0 \end{cases} \quad (2)$$

where

$p(\theta)$ = radial pressure distribution.

“This surprising result shows that the farfield sound pressure distribution is essentially equal to the pressure distribution on the surface of the sphere. Rogers and Van Buren also point out that because the surface pressure and velocity are nearly zero over the inactive part of the outside surface of the sphere, the part of the rigid spherical shell outside the spherical cap region can be removed without significantly changing the acoustic radiation. This means that the ideal constant beamwidth behavior of the spherical cap is retained even though the rest of the sphere is missing!”

“The Legendre function $P_\nu(\cos\theta)$ is equal to one at $\theta = 0$ and has its first zero at angle $\theta = \theta_0$, the half angle of the spherical cap. The Legendre function order (ν) is chosen so that its first zero occurs at the half angle of the spherical cap. Note that ν is normally greater than one, and not necessarily an integer.”

“Rogers and Van Buren also point out that the constant beamwidth behaviour of a rigid spherical cap also applies as well to an acoustically transparent spherical shell. However the acoustic radiation is bidirectional, generating the same beam pattern front and rear.”

“To sum up the advantages of the CBT I quote from [1]:

“We enumerate the expected properties of the CBT above cutoff:

- (1) Essentially constant beam pattern.
- (2) Very low sidelobes.
- (3) The surface distribution as well as the pressure distribution at all distances out to the farfield is approximately equal to the surface distribution. Thus in a sense, there is no nearfield.
- (4) Since both the surface velocity and surface pressure have the same dependence on θ , the local specific acoustic impedance is independent of θ (and equal to $\rho_0 c$). Thus the entire transducer is uniformly loaded.”

Keele [3] extends the CBT theory to loudspeaker arrays and provides a simplified four-term series approximation to the Legendre shading of Eq. (1) which is acceptable over all useful Legendre orders:

$$U(x) \approx \begin{cases} 1 + 0.066x - 1.8x^2 + 0.743x^3 & \text{for } x \leq 1 \\ 0 & \text{for } x > 1 \end{cases} \quad (3)$$

where

$$x = \text{normalized angle} \left(\frac{\theta}{\theta_0} \right)$$

Note that this function is exactly 1 at $x = 0$ and 0 at $x = 1$ (where $\theta = \theta_0$ the half cap angle). All the following simulations use eq. (3) as a substitute for the Legendre function of Eq. (1).

As pointed out in [3], the coverage angle (6-dB-down beamwidth) of the CBT array is approximately 64% of the cap angle or circular-arc angle.

1.2 Review: Application of CBT Theory to Line Arrays

Keele [3] extended the CBT theory to circular-arc line arrays. Here the array is a circular-arc or wedge, usually oriented with its long axis vertical, which provides a controlled vertical coverage pattern and an uncontrolled horizontal coverage pattern.

Figure 1 shows a depiction of the side view of an example 120° circular-arc line array with 13 drivers along with the required CBT processing. The required Legendre shading is indicated with processing blocks showing the required attenuation of each driver. Note that the center driver is not

attenuated, while the remaining drivers are progressively attenuated more and more as the driver's position reaches the outside edge of the array according to Eq. (3).

To prevent the outside drivers from being turned off because they lie on the outside edge of the arc, the array was artificially increased in length by one driver-to-driver center spacing (adding one-half space to either end) to effectively position the outside drivers in the arc rather than on the edge.

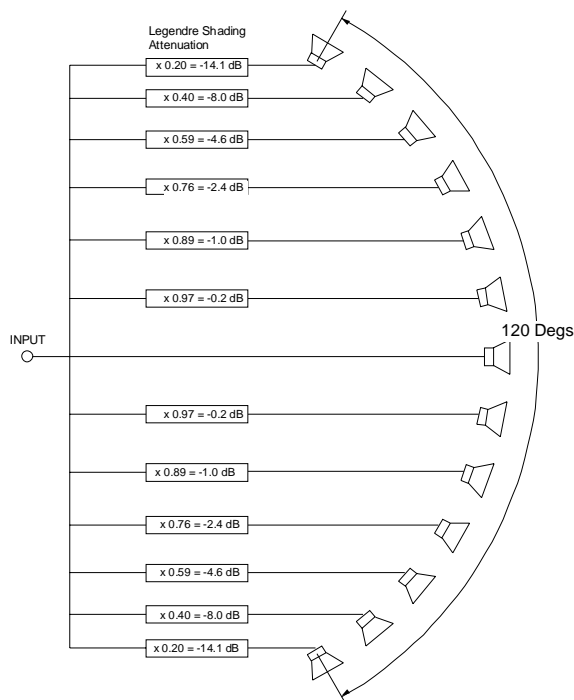

Fig. 1. Conventional CBT circular-arc line array with required processing. The array is depicted as a 120°-arc with 13 drivers. Note that the frequency-independent attenuation-only Legendre shading can be accomplished passively or by other means such as manipulating driver impedances.

To simplify the Legendre shading, the speakers may be divided into sub groups and driven with equal levels. This effectively creates a stepped approximation to the shading and may perform acceptably well in many situations [3, Sections 3.3.6 and 3.3.7].

1.3 Delay-Derived CBT Arrays

In the conventional CBT line or surface array the drivers are positioned around an arc or on the surface of a sphere (or on the surface of a torus as suggested

by Keele [3]). This spatial positioning and the Legendre shading provides the primary array characteristics that generate the constant beamwidth and coverage control of the array's acoustic output.

As an alternate to actual physical spatial positioning, signal delays may be used to approximate the required shapes in conjunction with straight-line or flat configurations of drivers. The signal delay effectively moves the driver from its position on a straight-line or flat surface to a point on a circular arc or on the surface of a sphere.

It is expected that this delay approximation to the actual physical positioning of the drivers works less well for extreme off-axis angles. As will be shown later, these so-called "delay-derived" CBT arrays exhibit a widening of the polar pattern for off-axis angles greater than about 60°.

Figure 2 shows a depiction of a straight-line array with the required processing to create a delay-derived CBT line array. Each driver is driven by a separate channel which consists of an attenuation block that provides the Legendre shading, a signal delay that provides an approximation to the CBT spatial positioning, and a power amplifier to drive the speaker.

Note that the conventional CBT array may not require power amplifiers driving each speaker because the required Legendre shading may be done passively. Additionally, note that all the processing for the delay-derived CBT array is frequency independent i.e., each speaker's processing channel forms an all-pass filter with prescribed gain and delay, both of which are independent of frequency.

Although not analyzed here, the acoustic output of the delay-derived CBT arrays may be steered by simply changing the delay values to effectively tilt the array in the direction of the desired steering angle. This is in contrast to the conventional CBT array where there is no easy way to steer the array without physically reaming the array or by using more drivers and rotating the shading function around the array, thus using only a fraction of the drivers.

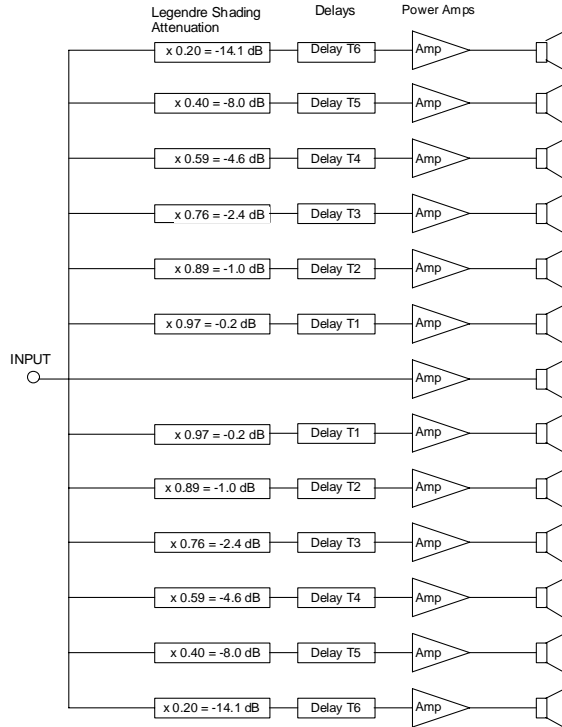

Fig. 2. Delay-derived CBT straight line array with required processing. The array is depicted as a straight-line array with 13 drivers. Note the addition of signal delays and amplifiers required to approximate the arc of a conventional CBT array (Fig. 1). Note also that all processing is frequency independent.

Calculation of Delays and Shading

The required delays and shading may be calculated by referring to Fig. 3 and the following equations. The sources are assumed to be equally spaced along the axis of the line array. The added signal delays virtually shift the drivers straight back from their position on the straight line axis of the array to a point on the virtual CBT arc. The Legendre shading was calculated by mapping the shading function directly to position on the straight line i.e., the shading is maximum in the center of the array and minimum at the top and bottom.

Note that this method essentially starts with sources equally-spaced on the line array and then transfers them back to the virtual arc. This method in effect leaves the sources unequally spaced on the arc. An alternate calculation method would be to start with the sources equally-spaced around the virtual arc and then shifting them forward to the straight line. This latter method was judged not quite as desirable because the sources would then be unequally spaced

on the straight line. Typically the sources or drivers are equally spaced in the line array and spaced as close together as possible.

The radius of the CBT arc is given by

$$R = \frac{H_T}{2 \sin\left(\frac{\theta_T}{2}\right)} \quad (4)$$

where R = radius of arc,

H_T = overall height of arc (assumed to be equal to the height of the straight line array), and

θ_T = included angle of arc.

The angular position of a specific source on the arc is given by

$$\theta_s = \sin^{-1}\left(\frac{h}{R}\right) \quad (5)$$

where θ_s = source angle, and

h = source height.

The required offset D to position the source on the arc is given by

$$D = R(1 - \cos \theta_s) \quad (6)$$

where D = source offset.

Finally the required delay τ is given by

$$\tau = D / c \quad (7)$$

where τ = offset delay, and

c = speed of sound.

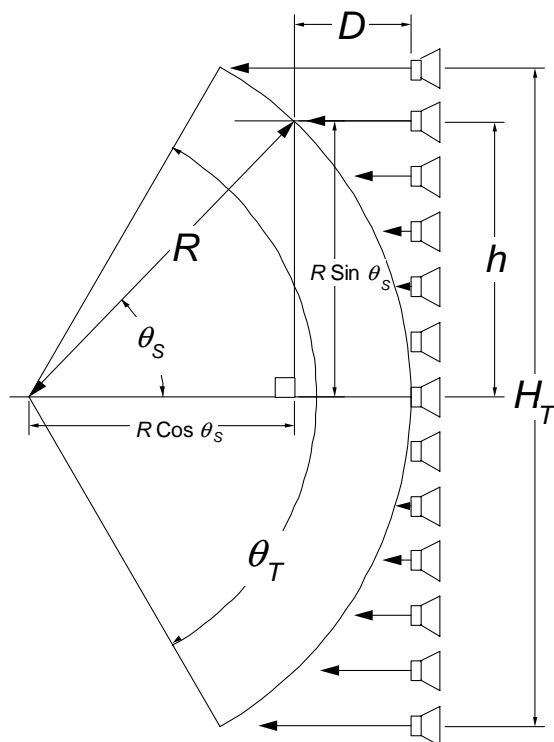

Fig. 3. Relationships required to calculate the delays for the delay-derived CBT array. The delay effectively moves the driver from its position on a straight-line or flat surface to a point on a circular arc or on the surface of a sphere.

2. ARRAY SIMULATIONS

The point-source array simulator program used in [3] was used here to predict the directional characteristics of the various arrays. This program calculates the pressure distribution at a specific distance (all simulations here are done at a distance of 25m) for a 3-D array of point sources of arbitrary magnitude and phase.

Polar rotations were all done around the center of the coordinate system. Note that all the conventional curved CBT arrays were offset so that their centers of curvature coincided with the center of the coordinate system.

Program outputs include (quoting from [3]):

“1. Source configuration views as seen from front, top, and sides with approximate magnitude shading indicated by source size.

2. Horizontal and vertical beamwidth (-6dB) vs. frequency plots at each one-third-octave center from 20 Hz to 16 kHz.

3. Directivity index and Q vs. frequency plots at each one-third-octave center from 20 Hz to 16 kHz.

4. On-axis frequency response (loss) plot vs. frequency (compared to all sources on and in-phase at the pressure sampling point). This plot indicates how much on-axis attenuation the array imposes as compared to the situation where all the sources add in phase at the sampling point.

5. Complete set of horizontal and vertical polar plots at all one-third octaves over the frequency range of 630 Hz to 20 kHz. The polar displays have 0 dB on the outside edge and -40 dB in the center with a grid circle spacing of 10 dB. The -6dB grid circle is also drawn.

6. Complete set of $\pm 60^\circ$ horizontal x $\pm 60^\circ$ vertical footprint plots at all one-third octaves over the frequency range of 630 Hz to 16 kHz. In each footprint plot, the pressure in dB is normalized to the maximum in the stated angular range and is shown as a gray-scale density plot (high pressure in white and low in black).”

3. COMPARE CONVENTIONAL vs. DELAY-DERIVED CBT LINE ARRAYS by VARYING COVERAGE ANGLES

3.1 Description

The coverage of the conventional CBT circular-arc line array was compared to the coverage of a delay-derived CBT straight line array by designing four separate arrays of each type to provide coverage angles (6-dB-down beamwidths) of 12.5° , 25° , 50° , and 100° . These coverages required arc angles of 19.5° , 39° , 78° , and 156° respectively (remember that the coverage angle is approximately 64% of the arc angle). All eight arrays were designed to be two wavelengths high at 1 kHz i.e., 27 inches (0.69) meters (assuming a speed of sound of 343 m/sec). The number of sources in each array was varied so that the center-to-center spacing was about 1 inch (25 mm).

The array characteristics and their predicted acoustic output is shown in Appendix 1. Appendix 1 contains the following: a table containing the characteristics of each of the arrays (Table 2), side-view depictions of each array (Fig. 6), comparative graphs of vertical beamwidth (Fig. 7), directivity index (Fig. 8), on-axis frequency (loss) response (Fig. 9), $\pm 90^\circ$ off-axis

rejection plots vs. coverage angle (Fig. 10), horizontal (Fig. 11) and vertical (Fig. 12) polar plots at 4 kHz, and footprint plots at 4 kHz (Fig. 13). A frequency of 4-kHz was chosen because it is mostly in the operating band of all the arrays which extends from about 1 to 10 kHz.

3.2 Results

Refer to the figures in Appendix 1 for the following comments.

The plots of vertical beamwidth vs. frequency (Fig. 7) indicate that the conventional and delay-derived CBT arrays are quite similar for coverage angles of 50° and less. However, the widest-angle arrays providing 100° coverage have clearly different beamwidth characteristics. The delay-derived CBT array exhibits a beamwidth roll-off above 4 kHz which results from interference due to the finite spacing of the sources.

The beamwidth plots also show the typical increase of the lower beamwidth control frequency as the angular coverage decreases [3, Eq. 3]. The control frequency increases in octave steps from roughly 600 Hz for the 100° array to 4.8 kHz for the 12.5° coverage.

The coverage control of the CBT array relies strongly on the spacing of sources being small with respect to the radiated wavelength. This requirement is violated at the higher frequencies. The interference increases at larger off-axis angles and creates ripples in the polar response that effectively widens the coverage but decreases the measured beamwidth because the first 6-dB-down polar crossing occurs at narrower angles.

The directivity vs. frequency plots (Fig. 8) compare the two arrays in this important parameter. The plots essentially show the same directivity behavior for both types of arrays. The drop in directivity above 10 kHz is a direct result of the interference due to the finite spacing of the sources

The on-axis frequency response (loss) plots (Fig. 9) show the characteristic 3-dB/octave roll-off of the CBT array through out its operating range. The responses are very similar except for the widest coverage angle where the delay-derived array deviates above 6 kHz.

Fig. 10 plots the $\pm 90^\circ$ vertical off-axis level at 4 kHz vs. coverage (-6 dB) angle for a series of conventional circular-arc CBT line arrays and delay-

derived CBT straight-line arrays designed for a series of coverage angles ranging over 6.4° to 115° (arc angles of 10° to 180°). Both arrays were 27 inch (0.69 m) high. Note that at wide arc angles the delay-derived CBT array only provides about 10 dB of $\pm 90^\circ$ off-axis rejection while the conventional CBT array provides a much greater rejection of about 25 to 35 dB.

The 4-kHz horizontal polars (Fig. 11) show the characteristic right-left widening of the polar response at $\pm 90^\circ$ for the conventional CBT array. This widening or off-axis bulge effect occurs because all the point sources are equally distant from the observation point at $\pm 90^\circ$ and thus add in phase. The delay-derived CBT array does not exhibit this widening effect because all the drivers are in a straight line and thus add up the same at all horizontal off-axis directions.

The 4-kHz vertical polars (Fig. 12), which are all normalized to the on-axis levels, exhibit very similar patterns except at the widest 50° and 100° coverage angles. Here the delay-derived array exhibits a widening of the polar pattern at extreme off-axis angles beyond 60° off axis.

The footprint plots (Fig. 13) reflect the widening of vertical response for the delay-derived CBT arrays at the wider coverage angles. Also evident is the rounding of the conventional CBT footprint as compared to the delay-derived footprint due to horizontal bulge effect.

4. DESIGN LINE-ARRAY FOR FLAT OFF-AXIS RESPONSE

The widening problem that exists for extreme off-axis angles for the delay-derived CBT array can be used to advantage to flatten the off-axis of the array for all off-axis angles. This essentially trades off-axis rejection for flatness of off-axis response.

Experimentally it was determined that a 70° coverage-angle delay-derived CBT array with a 110° virtual arc provided just such a condition.

A delay-derived CBT array was simulated with the following characteristics: 70° coverage angle, 110° arc angle, 27 inches (0.69 m) high, and 109 point sources. This high number of sources provides a close source-to-source spacing of only 0.25 inches (6.35 mm) which insures clean operation to beyond 20 kHz. This simulation essentially predicts the response of a continuous source up to 20 kHz.

Figure 4 shows the vertical on- and off-axis frequency response curves of the resultant delay-derived straight line CBT array. All curves have been normalized to the on-axis response. Note the uniformity of the curves all the way out to $\pm 90^\circ$ (up and down) of on axis. At $\pm 90^\circ$, the level is down a healthy 16.5 dB.

Figure 5 shows a typical polar response of this array which is maintained over the wide range of 1.25 to 20 kHz.

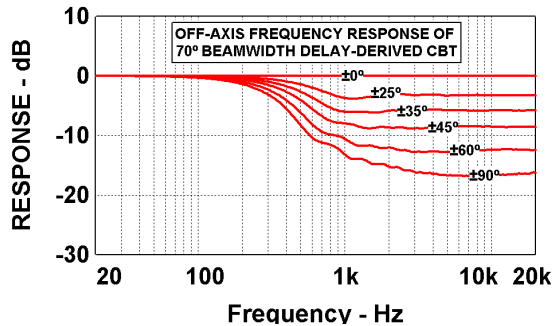

Fig. 4. Vertical off-axis frequency responses at 0, $\pm 25^\circ$, $\pm 35^\circ$, $\pm 45^\circ$, $\pm 60^\circ$, and $\pm 90^\circ$, of a 70°-beamwidth coverage delay-derived straight line CBT array of 27 inches (0.69m) height. This coverage angle was chosen to yield the flattest off-axis frequency response curves above 1 kHz over the whole range of vertical angles from 0° to $\pm 90^\circ$.

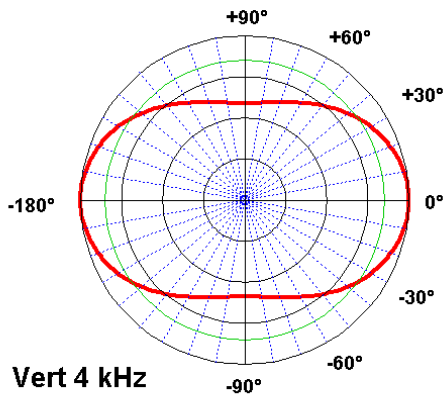

Fig. 5. Normalized vertical polar response at 4 kHz for the 70°-beamwidth CBT array of Fig.4. This response is typical of all the polar curves from 1.25 kHz and above. The outside of the graph is at 0 dB, the inside is at -40 dB, with 10 dB per major division. A circle (green) is drawn at the -6 dB down level as an aid to determine beamwidth.

5. SPHERICAL-CAP AND CIRCULAR FLAT-PANEL CBT ARRAYS

5.1 Description

To illustrate the performance of conventional curved-surface and flat-surface CBT arrays, two arrays were designed: 1) a spherical-cap CBT array and 2) a circular flat-panel delay-derived CBT array. Both arrays were 27 inches (0.69 m) in diameter (two wavelengths at 1 kHz), and were designed for a 40° coverage angle above about 1 kHz. The arc angles in both cases were 62.5° .

The spherical-cap array had 553 sources while the circular flat-panel array had 556. These number of sources provided a rough one-inch (25.4 mm) center-to-center source spacing for both arrays which provided well-behaved operation up to about 10 kHz.

Both arrays were designed with a single source in the center with 13 radial rings spaced one inch (25.4 mm) apart. The number of sources in each ring was chosen to make the center-to-center spacing of the sources as close as possible to one inch (25.4 mm). Each ring was driven separately with the appropriate Legendre shading and delay.

The following table lists the Legendre shading amplitudes and delays for each ring of the array.

TABLE 1: SOURCE SHADING and DELAYS for the CONVENTIONAL SPHERICAL-CAP and DELAY-DERIVED CIRCULAR FLAT-PANEL CBT ARRAYS

Ring Num.	Legendre Shading Amplitude	Conventional CBT Array Delay μ S	Delay-Derived CBT Array Delay μ S
0 (Center)	1.00 (0.0 dB)	0.000	0.00
1	0.996 (0.0 dB)	0.000	1.54
2	0.975 (-0.2 dB)	0.000	6.15
3	0.939 (-0.5 dB)	0.000	13.86
4	0.889 (-1.0 dB)	0.000	24.72
5	0.827 (-1.6 dB)	0.000	38.76
6	0.755 (-2.4 dB)	0.000	56.07
7	0.675 (-3.4 dB)	0.000	76.73
8	0.587 (-4.6 dB)	0.000	100.87
9	0.494 (-6.1 dB)	0.000	128.61
10	0.396 (-8.0 dB)	0.000	160.13
11	0.297 (-10.5 dB)	0.000	195.64
12	0.196 (-14.2 dB)	0.000	235.39
13 (Outside)	0.097 (-20.3 dB)	0.000	279.68

5.3 Results

Appendices 2 and 3 provide additional information and simulation results for the spherical-cap and circular flat-panel CBT arrays. Expanded front and side views of the array configurations are shown on the first page of each appendix (Figs. 14 and 20).

Conventional Spherical-cap CBT Array

Refer to the information in Appendix 2 (Figs. 15 - 19) for the following comments.

The beamwidth vs. frequency graph (Fig. 15b) shows a fairly uniform beamwidth in both planes of about 40° from about 1.25 to 16 kHz. The directivity index vs. frequency graph (Fig. 16c) indicates a fairly uniform value of 13.5 ± 1 dB from 1.25 to 10 kHz. The on-axis (loss) frequency response (Fig. 16d) shows a uniform roll-off of 6-dB/octave (20-dB/decade) above 1.25 kHz.

The normalized horizontal and vertical polar graphs (Figs. 17 and 18) indicate a very uniform bi-directional petal pattern between 1.25 and 10 kHz. Above 10 kHz, the polar response grows very irregular and broad because the source spacing is comparable or greater than wavelength. The on-axis footprints (Fig. 19) exhibit a uniform circular pattern between 1 and 10 kHz. The breakdown and randomization of the radiation pattern is very evident above 10 kHz.

Delay-Derived Circular Flat-Panel CBT Array

Refer to the information in Appendix 3 (Figs. 21 - 25) for the following comments.

All the data for the delay-derived CBT array is very close to the corresponding data for the conventional CBT array. Some polar widening is evident for extreme off-axis angles beyond 60° . At high-frequencies, the response breakdown commences slightly lower in frequency at 8 kHz.

6. CONCLUSIONS

This paper has described a method of designing Constant Beamwidth Transducer (CBT) systems that are based on straight-line and flat-surface array configurations, rather than the required circular arcs and curved surfaces of conventional CBT arrays. Unfortunately, the arrays require much more complex processing than that required by the conventional CBT arrays.

The required processing includes multiple channels of signal delays and power amplifiers. Fortunately, all processing is frequency independent and thus is

much easier to implement. The signal delays are used to approximate the required curved lines and surfaces of the conventional CBT array.

Recall that the conventional CBT array requires only simple changes in source level (attenuation only) to implement the required Legendre shading. No other processing is required. The shading can be implemented passively if desired.

The following lists some of the advantages and disadvantages of the delay-derived CBT array.

Advantages:

1. Provides extremely uniform beamwidth, directivity, and off-axis frequency response over a wide bandwidth (an advantage shared with conventional CBT arrays).
2. The array is based on straight-line and flat-panel configurations. These shapes are easier to work with and more convenient from a practical standpoint than the curved lines and surfaces of the conventional CBT array..
3. The coverage angle of the array can be changed by just simply changing delay values.
4. All processing is frequency independent.
5. The array can be steered by simply changing delay values. The delay changes effectively tilt the array in the desired direction.
6. Does not exhibit the $\pm 90^\circ$ right-left horizontal polar bulge or pressure build up exhibited by the conventional CBT array.
7. Power rolloff through the operational pass-band is only 3 dB/octave for the straight-line array and 6-dB/octave for the flat-panel array (an advantage in common with conventional CBT arrays).

Disadvantages:

1. Is relatively complex because it requires separate channels of delays and power amplifiers.
2. Exhibits widening of polar response at extreme off axis angles as compared to the conventional CBT array. This can be used to advantage in some situations.
3. Requires the use of a large number of small identical wide-band transducers (a disadvantage in common with conventional CBT arrays). Well behaved operation to 10 kHz requires a source spacing of no more than 1 in (25 mm) which implies transducers no larger than about 0.95 in (24mm). This

could be a potential advantage when manufacturing economies of scale are considered due to the large number of transducers required.

7. ACKNOWLEDGEMENT

Many thanks go to Doug Button, Vice President Research and Development of JBL Professional, for first suggesting that delay could be used to create CBT arrays from straight line and flat surface arrays. He originally called the two types of arrays “time-curved” and “physically-curved” CBT arrays.

I originally rejected the idea out of hand, but was pleasantly surprised at how well they worked when I tried some further simulations. These preliminary simulations inspired the work described in this paper.

8. REFERENCES

- [1] P. H. Rogers, and A. L. Van Buren, "New Approach to a Constant Beamwidth Transducer," *J. Acous. Soc. Am.*, vol. 64, no. 1, pp. 38-43 (1978 July).
- [2] A. L. Van Buren, L. D. Luker, M. D. Jevnager, and A. C. Tims, "Experimental Constant Beamwidth Transducer," *J. Acous. Soc. Am.*, vol. 73, no. 6, pp. 2200-2209 (1983 June).
- [3] D. B. Keele, Jr., "The Application of Broadband Constant Beamwidth Transducer (CBT) Theory to Loudspeaker Arrays," 109th Convention of the Audio Engineering Society, Preprint 5216 (Sept. 2000).
- [4] D. L. Klepper, D. W. Steele, "Constant Directional Characteristics from a Line Source Array," *J. Aud. Eng. Soc.*, vol. 11, no. 3, pp. 198 (1963).
- [5] D. G. Meyer, "Multiple-Beam, Electronically Steered Line-Source Arrays for Sound Reinforcement Applications," *J. Aud. Eng. Soc.*, vol. 38, no. 4, (April 1990).

APPENDIX 1: VARY COVERAGE ANGLE: COMPARE CONVENTIONAL CBT LINE ARRAY TO DELAY-DERIVED CBT LINE ARRAY

This appendix describes a series of line arrays along with their simulation outputs that compare conventional circular-arc CBT arrays to delay-derived straight-line CBT arrays designed for a sequence of coverage angles. Four arrays of each type were designed (eight in all) for coverage angles (6-dB-down beamwidths) of 12.5°, 25°, 50°, and 100°. These required arc angles of 19.5°, 39°, 78°, and 156° respectively. All eight arrays were designed to be two wavelengths high at 1 kHz i.e., 27 inches (0.69) meters. The number of sources in each array was varied so that the center-to-center spacing was maintained at about 1 inch (25 mm). Refer to Section 3 of the main text for comments on the following table and graphs.

TABLE 2: CHARACTERISTICS OF CONVENTIONAL AND DELAY-DERIVED CBT LINE ARRAYS DESIGNED FOR VARIOUS COVERAGE ANGLES

(Note that the number of sources in each array was varied so that the center-to-center spacing was maintained at about 1 inch (25 mm).)

CBT Array Type and Number	Coverage Angle Degr	Arc Angle Degr	Array Height Inches (Meters)	Arc Radius Inches (Meters)	Number Sources
1. Conventional Circular Arc	12.5	19.5	27 (0.69)	79.7 (2.02)	28
2. Conventional Circular Arc	25	39	Same	40.4 (1.03)	28
3. Conventional Circular Arc	50	78	Same	21.4 (0.54)	29
4. Conventional Circular Arc	100	156	Same	13.8 (0.35)	37
5. Delay-Derived Straight Line	12.5	19.5 (Virtual)	Same	79.7 (2.02) (Virtual)	28
6. Delay-Derived Straight Line	25	39 (Virtual)	Same	40.4 (1.03) (Virtual)	28
7. Delay-Derived Straight Line	50	78 (Virtual)	Same	21.4 (0.54) (Virtual)	28
8. Delay-Derived Straight Line	100	156 (Virtual)	Same	13.8 (0.35) (Virtual)	28

Source Configurations (All Side Views)

12.5° Coverage Angle, 19.5° Arc Angle

CONVENTIONAL CBT

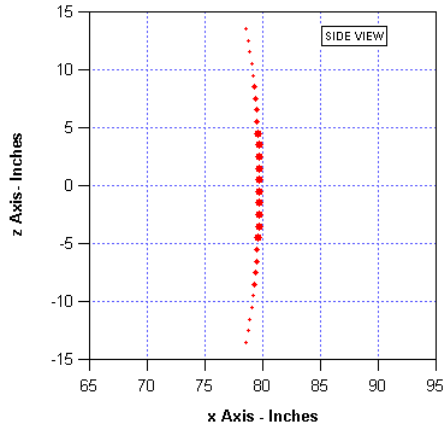

DELAY-DERIVED CBT

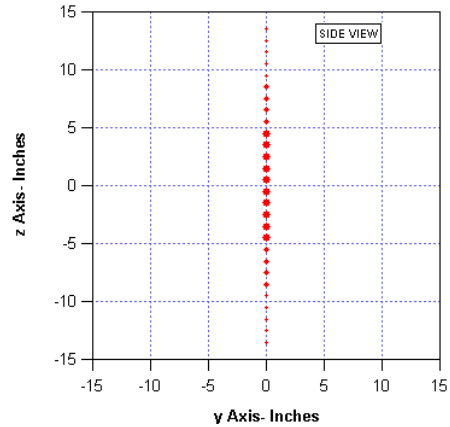

25° Coverage Angle, 39° Arc Angle

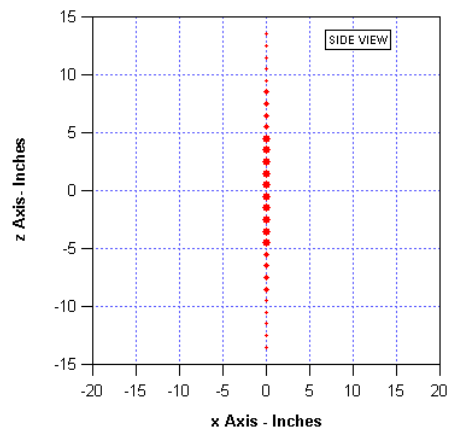
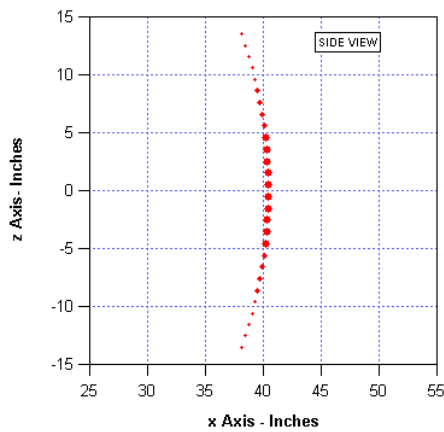

50° Coverage Angle, 78° Arc Angle

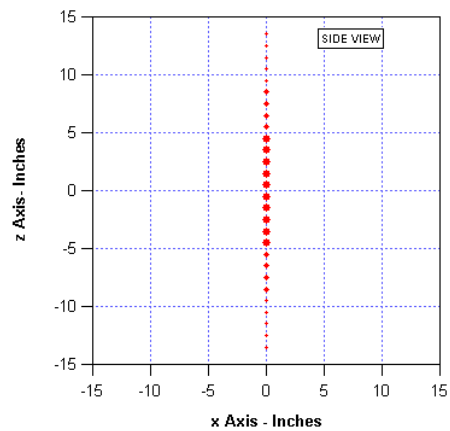
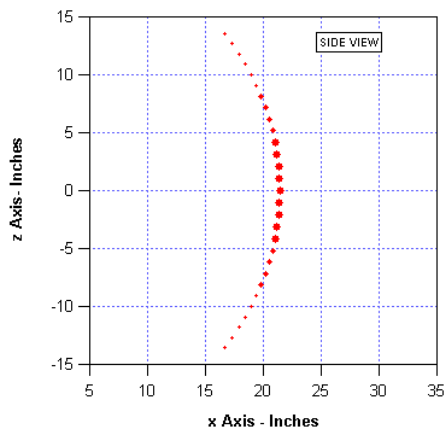
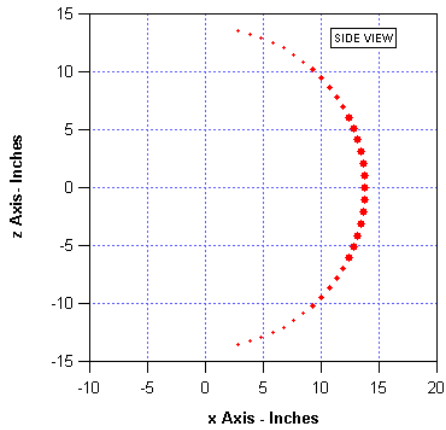

Fig. 6. See caption top figure of next page.

100° Coverage Angle, 156° Arc Angle
CONVENTIONAL CBT



DELAY-DERIVED CBT

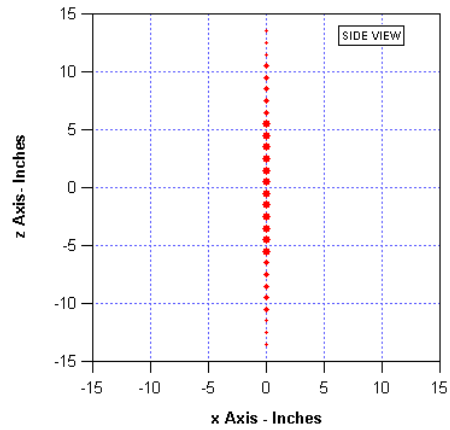

Fig. 6. Side views of the 27 inch (0.69 m) high CBT line arrays designed for coverage angles of: 12.5°, 25°, 50°, and 100° (top to bottom). The conventional circular-arc CBT array is shown in the left column and the delay-derived straight-line CBT array is shown in the right column. Source size is roughly proportional to shading magnitude.

Vertical Beamwidth vs. Frequency

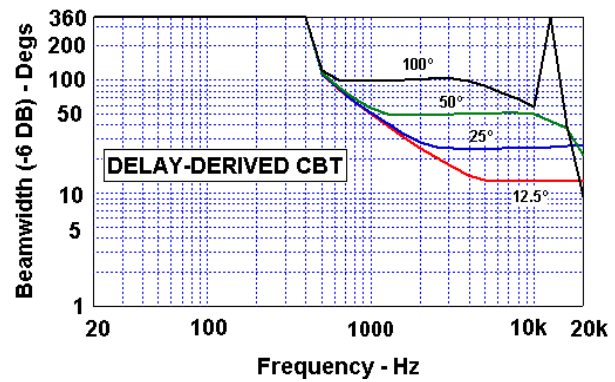
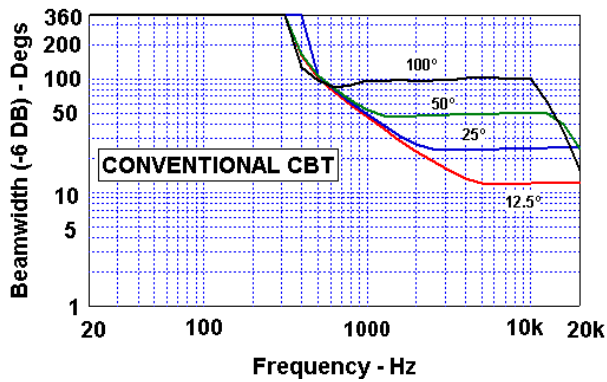

Fig. 7. Plots of vertical beamwidth vs. frequency for the 27 inch (0.69 m) high CBT line arrays designed for coverage angles of: 12.5°, 25°, 50°, and 100° (top to bottom curves in each plot). The conventional circular-arc CBT array is shown on the left and the delay-derived straight-line CBT array is shown on the right.

Directivity Index vs. Frequency

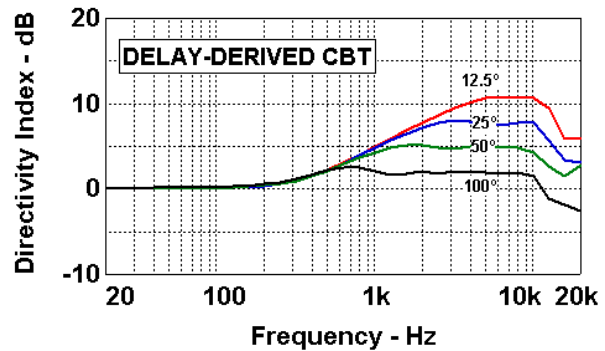
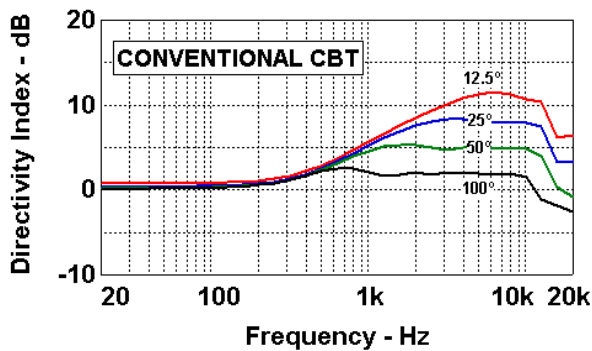

Fig. 8. Plots of directivity index vs. frequency for the 27 inch (0.69 m) high CBT line arrays designed for coverage angles of: 12.5°, 25°, 50°, and 100° (top to bottom curves in each plot). The conventional circular-arc CBT array is shown on the left and the delay-derived straight-line CBT array is shown on the right.

On-Axis Frequency Response

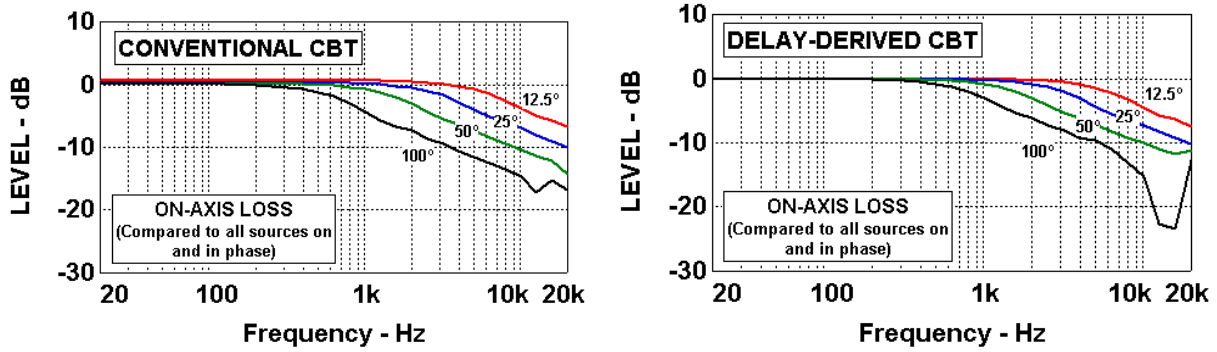

Fig. 9. Plots of on-axis frequency response (on-axis loss) for the 27 inch (0.69 m) high CBT line arrays designed for coverage angles of: 12.5°, 25°, 50°, and 100° (top to bottom curves in each plot). The conventional circular-arc CBT array is shown on the left and the delay-derived straight-line CBT array is shown on the right. The curves show the actual on-axis response compared to the response of all the sources arriving at the observation point in phase.

CBT Array ±90° Vertical Off-axis Level vs Coverage Angle

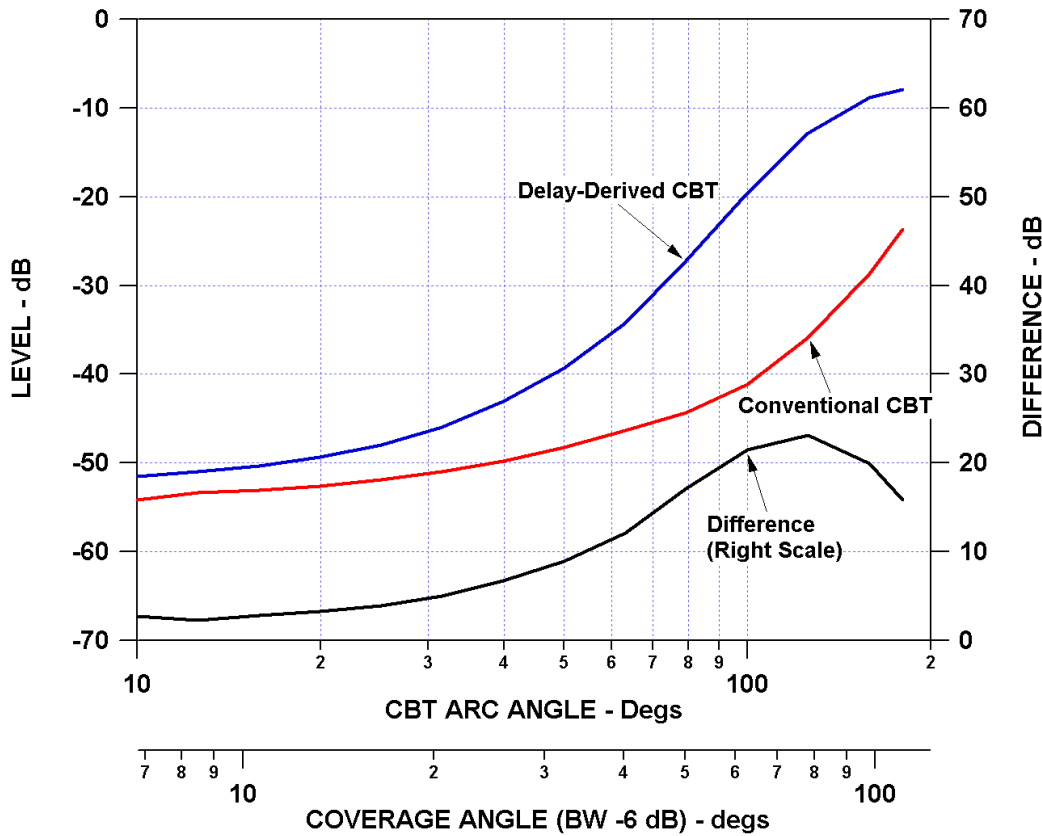

Fig. 10. Plots of the ±90° vertical off-axis level at 4 kHz vs. coverage (-6 dB) angle for a conventional circular-arc CBT line array and a delay-derived CBT straight-line array. Both arrays were 27 inch (0.69 m) high. To generate the data, a series of arrays with coverage angles ranging over 6.4° to 115° (arc angles of 10° to 180°) in third-octave steps were designed and simulated. The plotted levels were derived by averaging the 90° off-axis frequency response level in dB in an octave width centered at 4 kHz. Note that at a wide arc angle of 125°, which provides a coverage angle of 80°, the delay-derived CBT array only provides about 13 dB of ±90° off-axis rejection while the conventional CBT array provides a much greater rejection of about 36 dB.

Horizontal Polars at 4 kHz (*Not Normalized* to on axis)

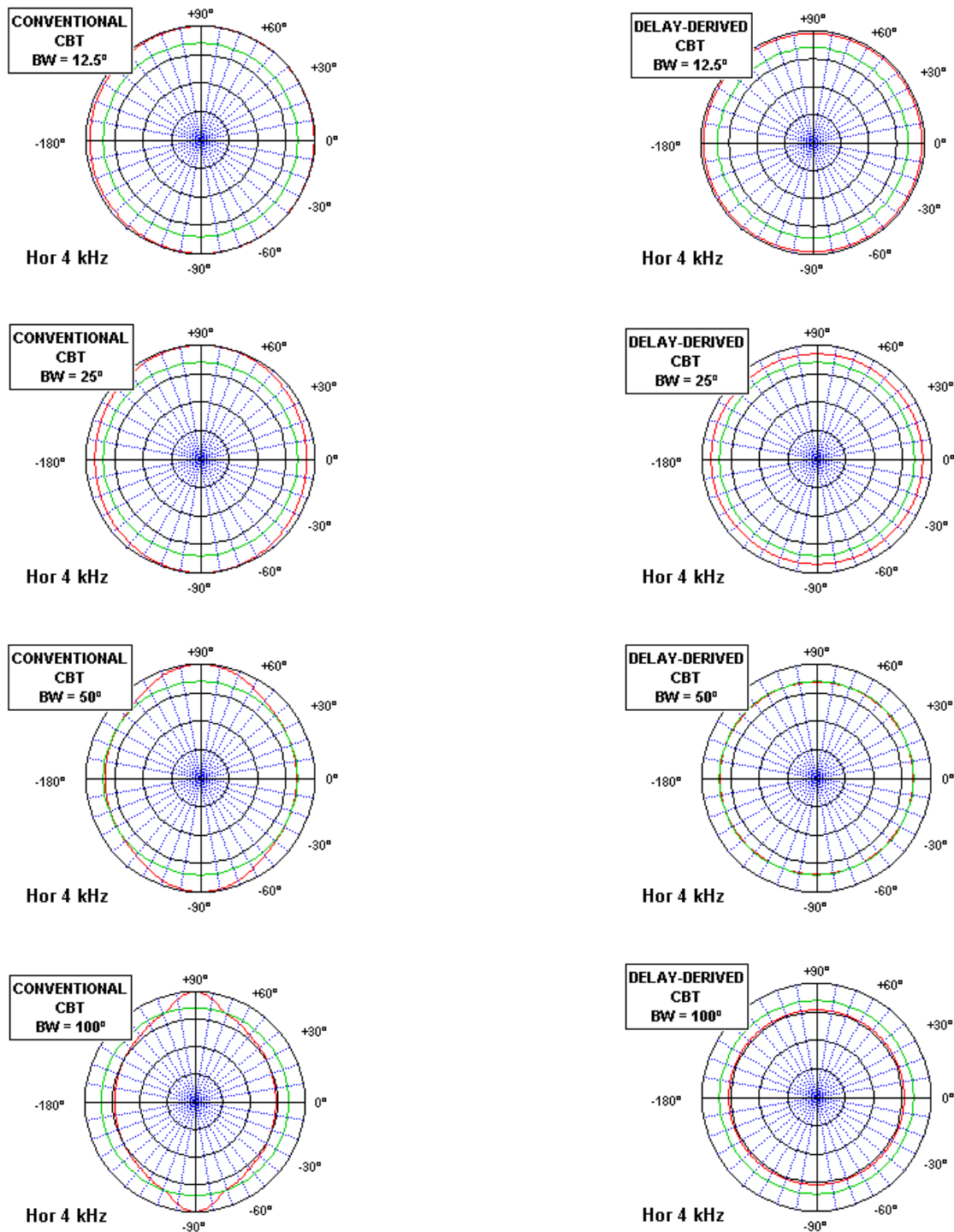

Fig. 11. Horizontal polar responses (un-normalized) at 4 kHz for the 27 inch (0.69 m) high CBT line arrays designed for coverage angles of: 12.5°, 25°, 50°, and 100° (top to bottom). The conventional circular-arc CBT array is shown in the left column and the delay-derived straight-line CBT array is shown in the right column. Note the $\pm 90^\circ$ right-left bulge in the responses for the conventional CBT array (left column). At $\pm 90^\circ$ all the sources are equidistant to the observation point and thus all arrive in phase. The delay-derived polars (right column) do not exhibit this problem because all the sources are aligned vertically and thus all signals arrive with the same phase at all horizontal observation points.

Vertical Polars at 4 kHz (*Normalized to on axis*)

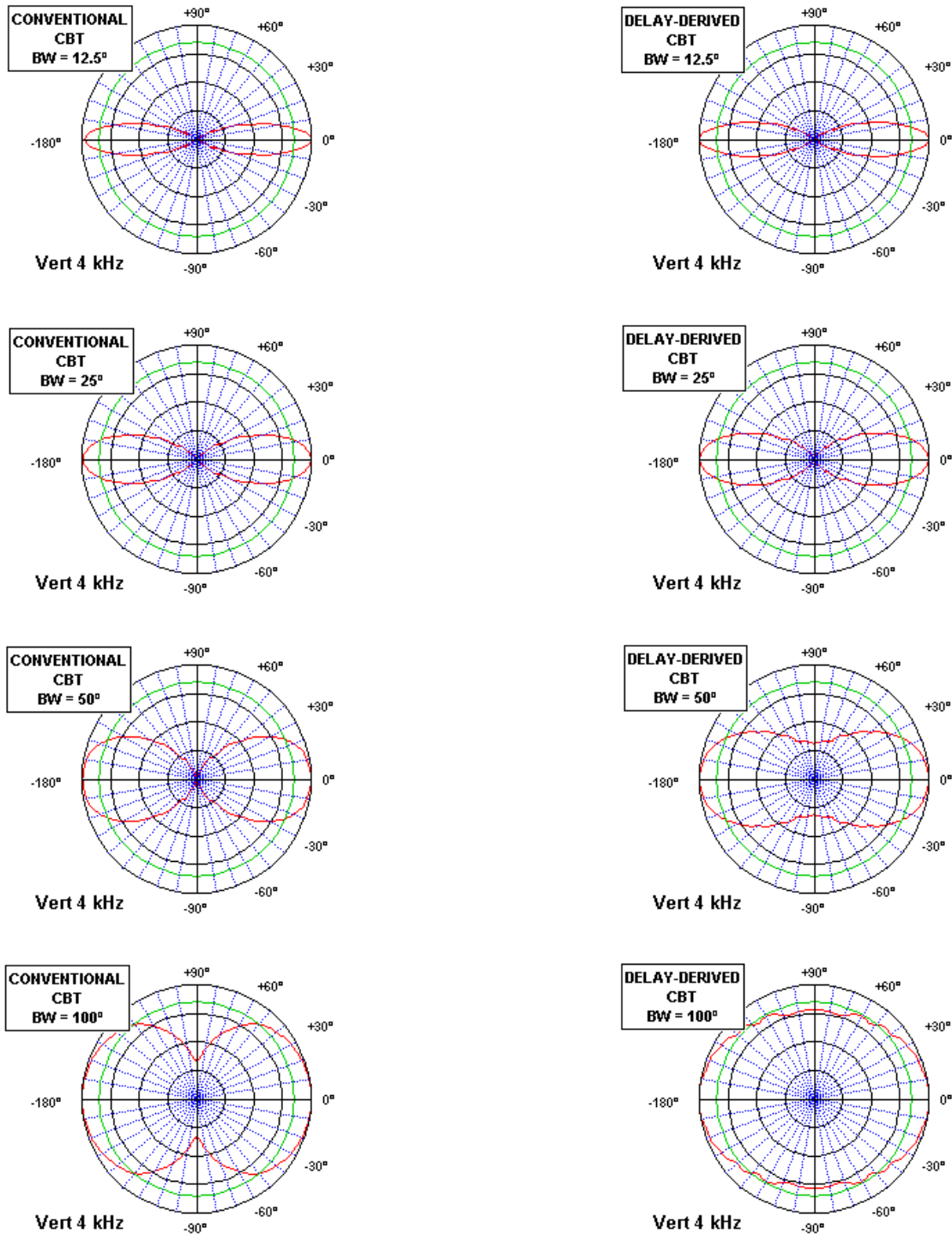

Fig. 12. Vertical polar responses (normalized) at 4 kHz for the 27 inch (0.69 m) high CBT line arrays designed for coverage angles of: 12.5°, 25°, 50°, and 100° (top to bottom). The conventional circular-arc CBT array is shown in the left column and the delay-derived straight-line CBT array is shown in the right column. Note that the polar responses are very similar at the lower coverage angles of 12.5° and 25° (upper two rows), but the delay-derived straight-line CBT array (right column) exhibits widening at extreme off-axis angles (up-down) for the higher 50°, and 100° coverage angles (lower two rows).

Footprints at 4 kHz

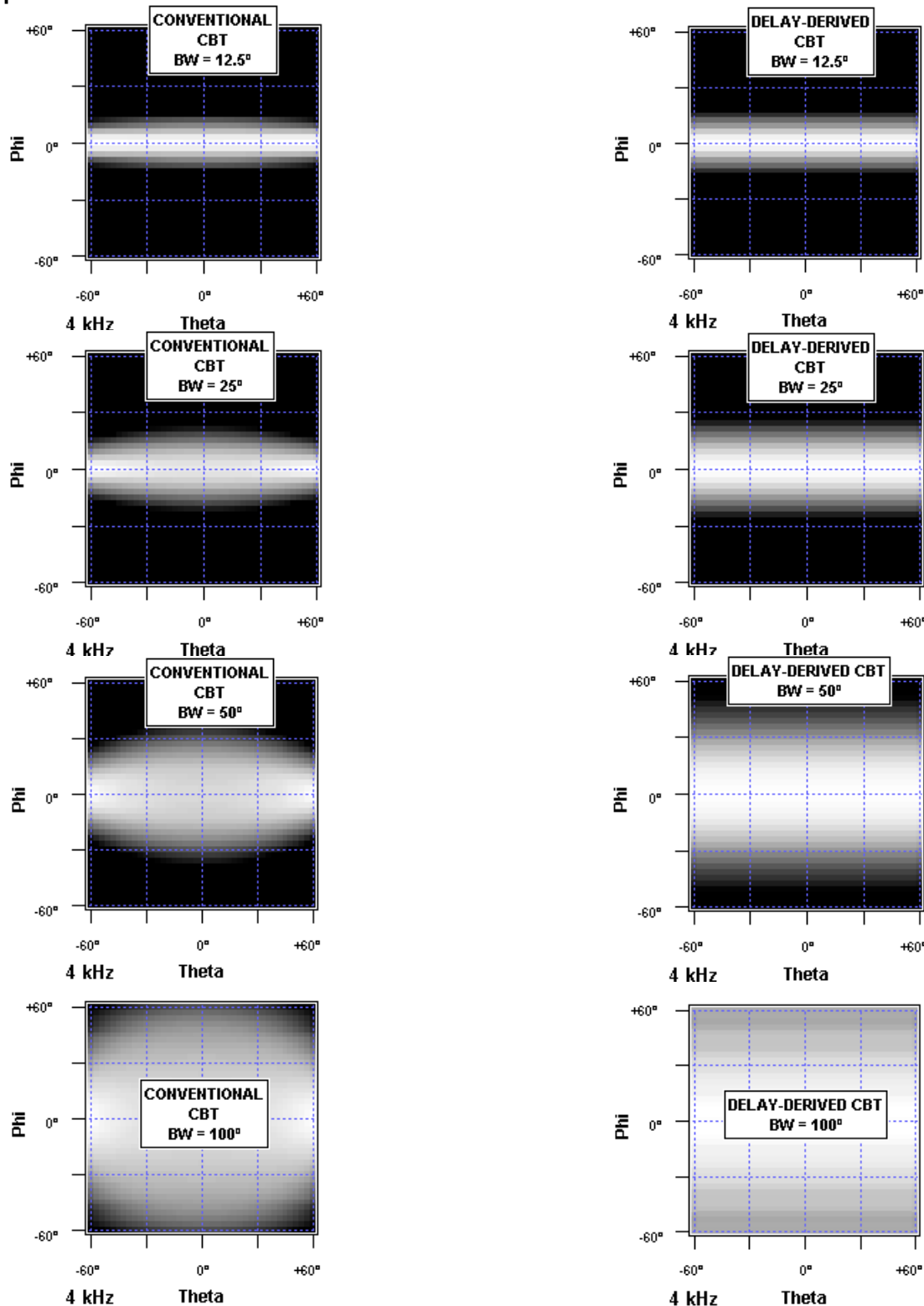

Fig. 13. On-axis footprint responses at 4 kHz for the 27 inch (0.69 m) high CBT line arrays designed for coverage angles of: 12.5°, 25°, 50°, and 100° (top to bottom). The conventional circular-arc CBT array is shown in the left column and the delay-derived straight-line CBT array is shown in the right column. Note the rounding of the footprints in the left column for the conventional CBT array and the wider vertical response (up-down) for the delay-derived CBT array in the right column at the higher coverage angles (bottom two rows).

APPENDIX 2: CONVENTIONAL CBT SPHERICAL-CAP ARRAY

This appendix describes a conventional spherical-cap CBT array that provides a 40° coverage angle with a 62.5° cap angle and gives its simulation results.

Conventional CBT Spherical-Cap Array, 40° Coverage Angle, 62.5° cap angle
Expanded Source Configuration

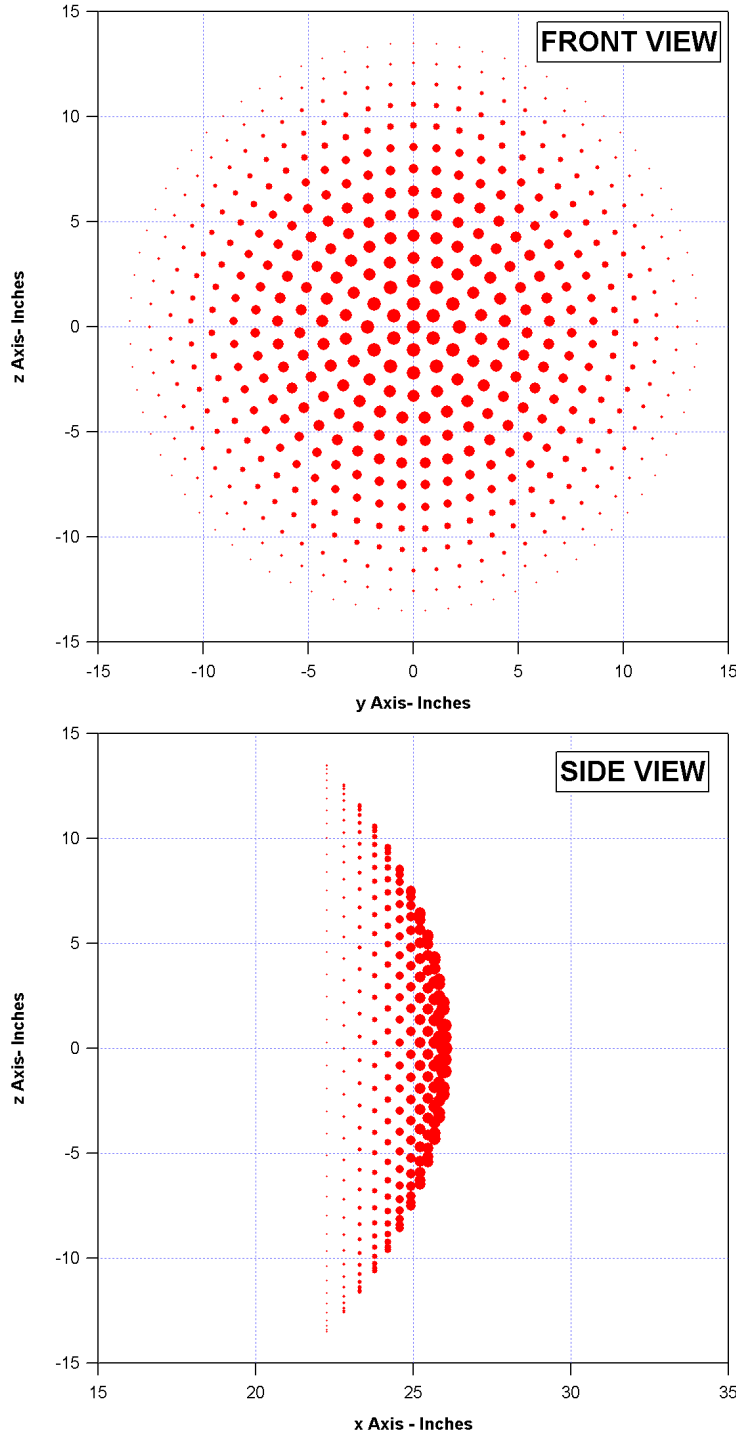

Fig.14. Expanded front and side views of the 27 inch (0.69 m) diameter (two wavelengths at 1 kHz) of the conventional spherical-cap CBT array designed for 40° coverage with a 62.5° cap (arc) angle. This array has 553 sources arranged in 13 radial rings with a single center source. Each ring was Legendre shaded with values given previously in Table 1. Compare this array with the delay-derived circular flat-panel array in the next appendix. Source size is roughly proportional to shading magnitude.

Source Configuration and Beamwidth

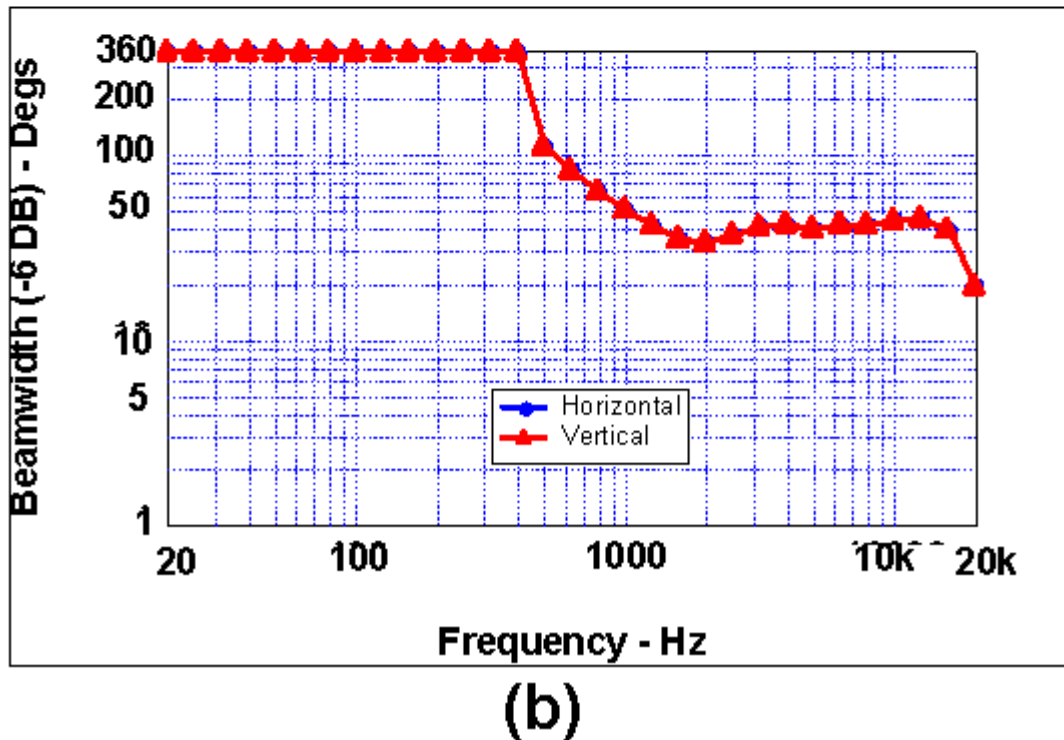
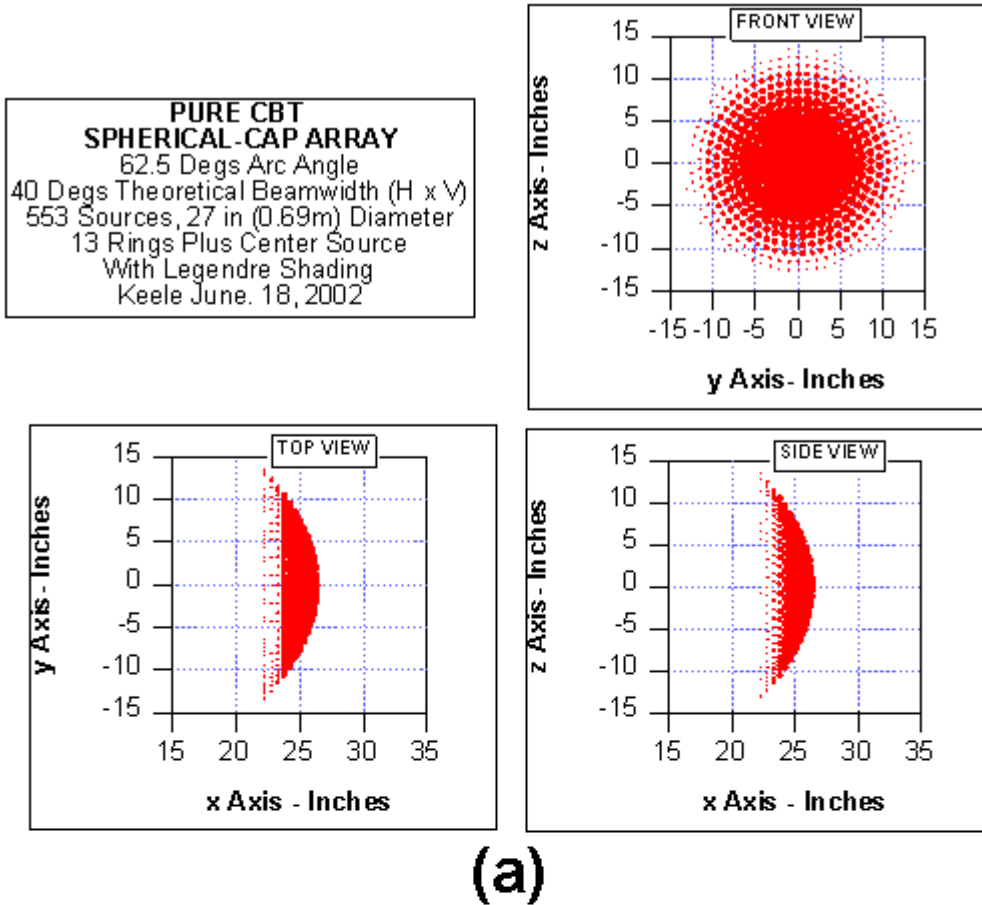
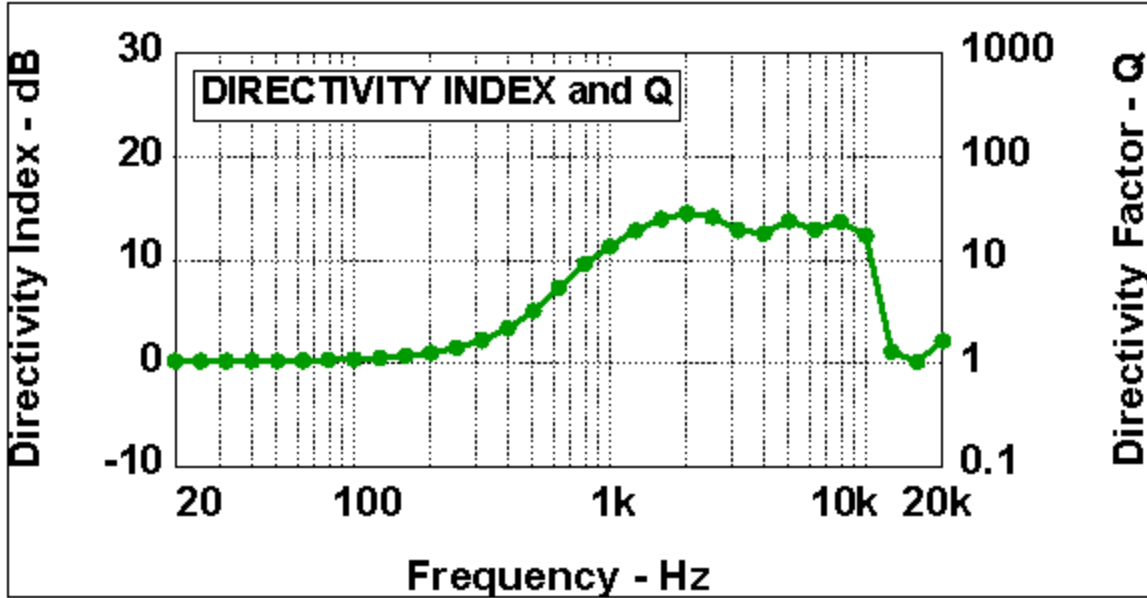
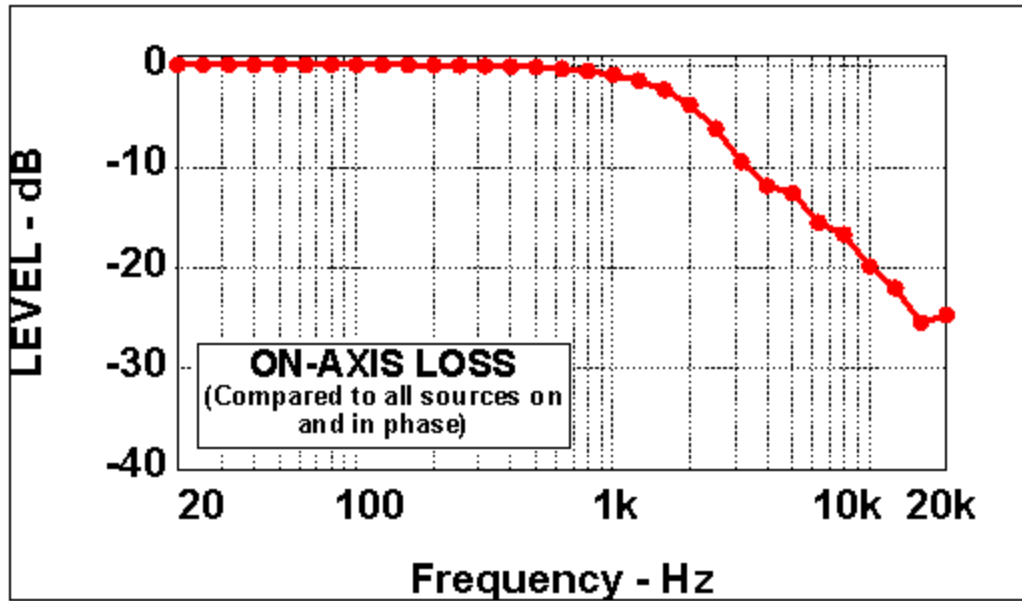

Fig. 15. (a) Source configuration and (b) beamwidth vs. frequency of the conventional spherical-cap CBT array designed for 40° coverage with a 62.5° cap (arc) angle of Fig. 14. Symmetrical array provides equal horizontal and vertical beamwidths.

Directivity and On-Axis Response



(c)



(d)

Fig. 16. (c) Directivity index and Q, and (d) on-axis frequency response (loss) of the conventional spherical-cap CBT array designed for 40° coverage with a 62.5° cap (arc) angle of Fig. 14. The directivity index vs. frequency graph indicates a fairly uniform value of 13.5 ± 1 dB from 1.25 to 10 kHz. The on-axis (loss) frequency response shows a uniform roll-off of 6-dB/octave (20-dB/decade) above 1.25 kHz.

Horizontal Polars (Normalized to on-axis level)

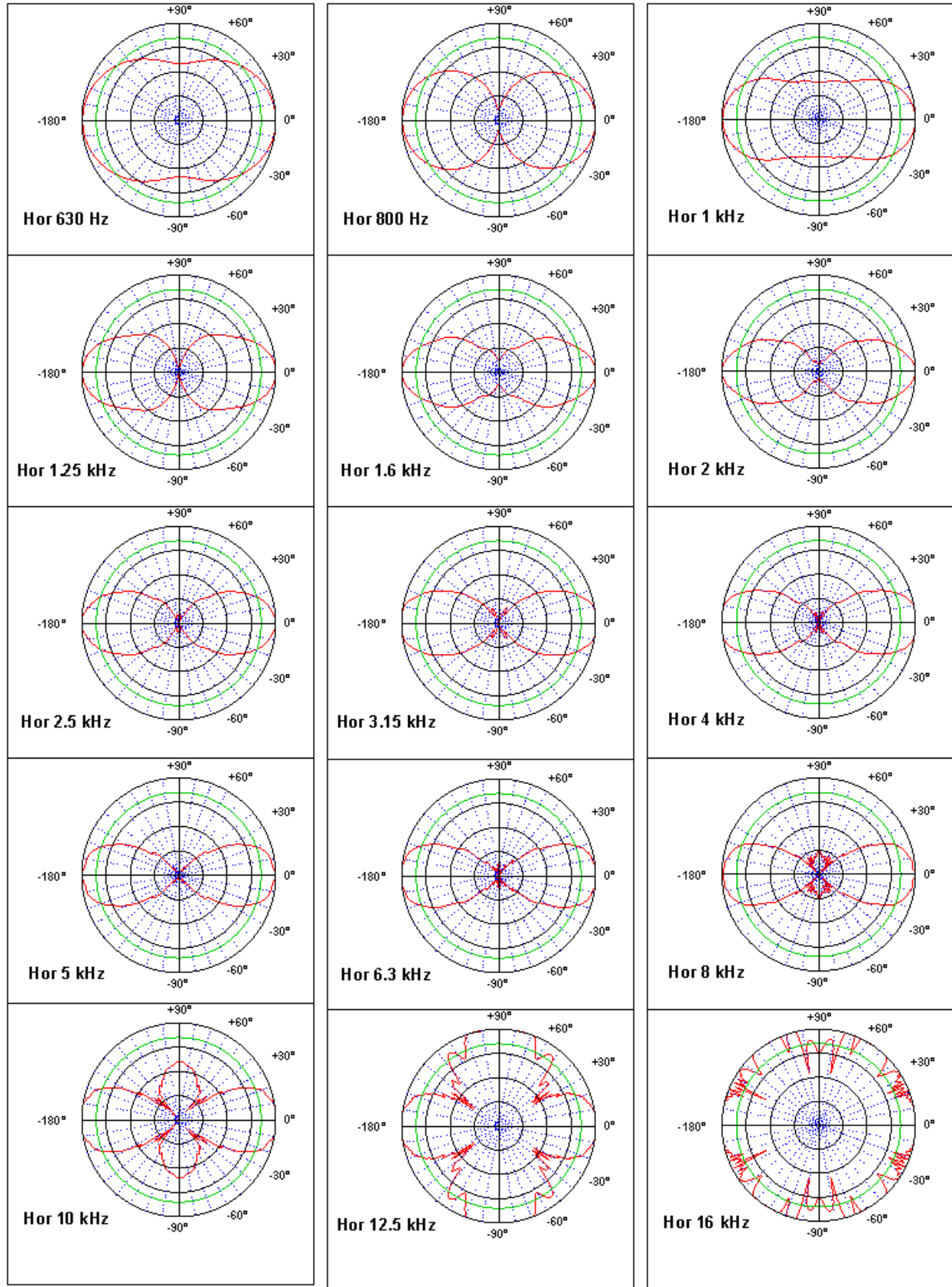

Fig. 17. Horizontal polars (normalized to the on-axis level) of the of the conventional spherical-cap CBT array designed for 40° coverage with a 62.5° cap (arc) angle of Fig. 14. Polars are quite uniform from 1.25 to 10 kHz.

Vertical Polars (Normalized to on-axis level)

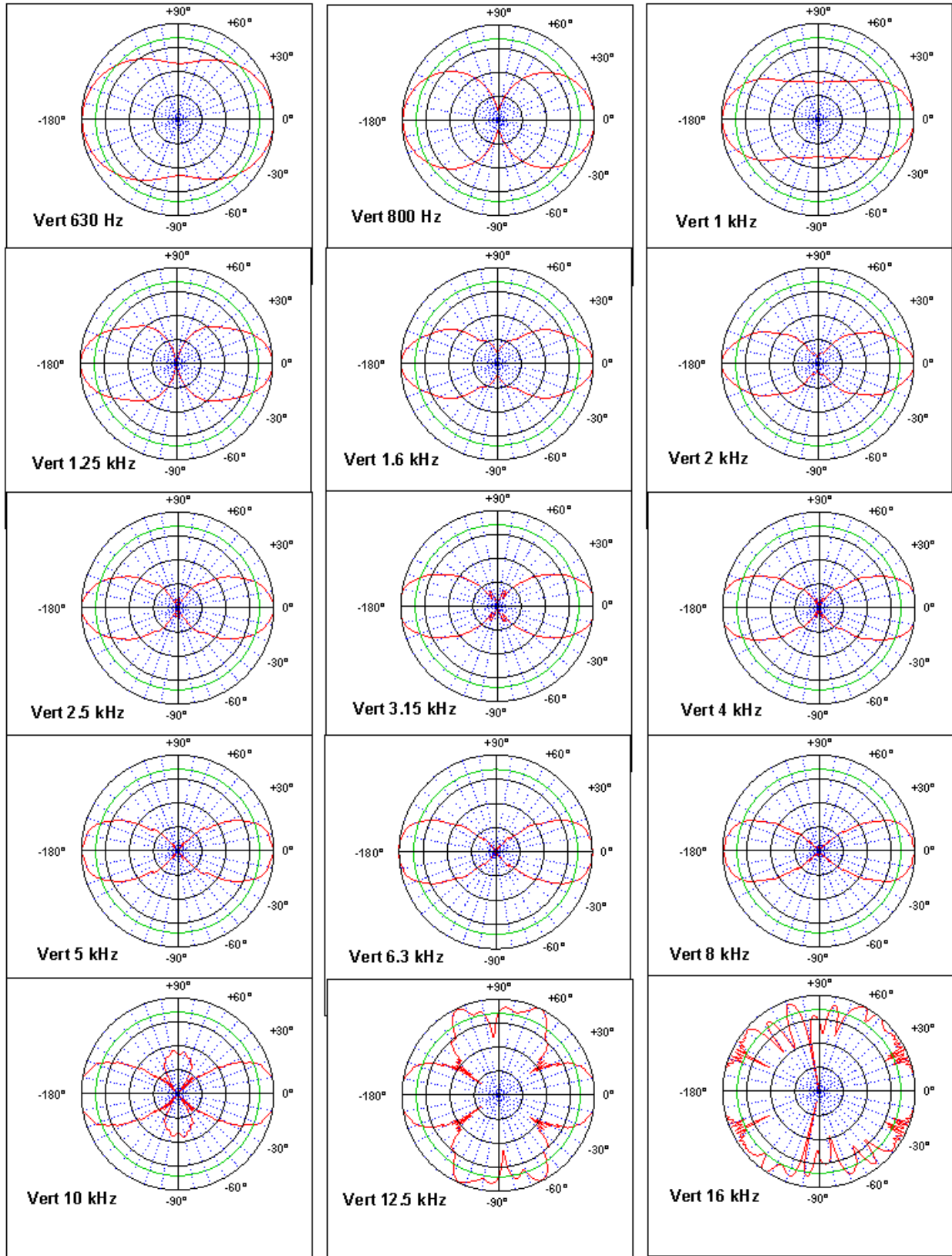

Fig. 18. Vertical polars (normalized to the on-axis level) of the of the conventional spherical-cap CBT array designed for 40° coverage with a 62.5° cap (arc) angle of Fig. 14. Polars are quite uniform from 1.25 to 10 kHz.

On-Axis Foot Prints

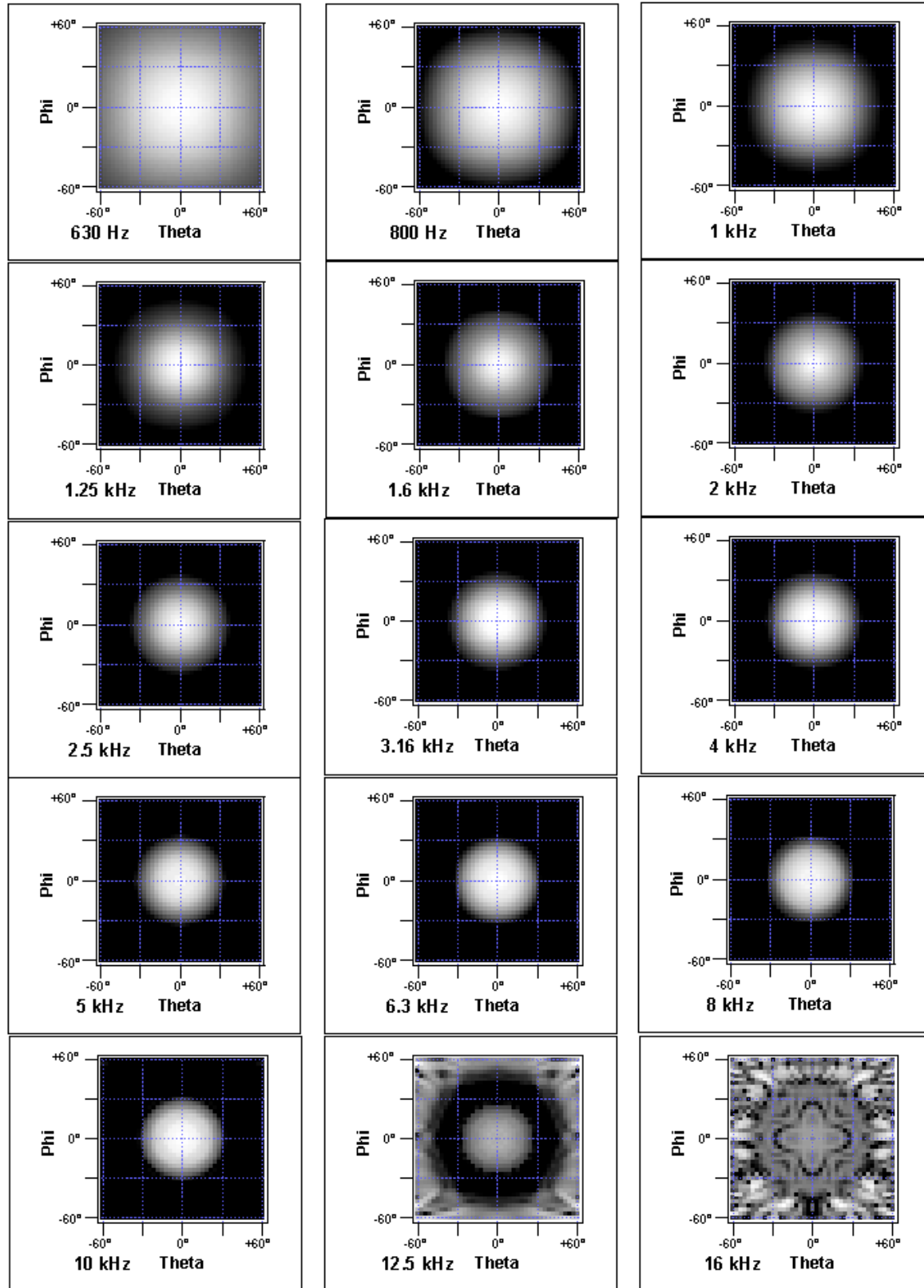

Fig. 19. On-axis footprints of the of the conventional spherical-cap CBT array designed for 40° coverage with a 62.5° cap (arc) angle of Fig. 14. Footprints are very uniform from 1 to 10 kHz.

APPENDIX 3: DELAY-DERIVED CBT CIRCULAR FLAT-PANEL ARRAY

This appendix describes a delay-derived circular flat-panel CBT array that provides a 40° coverage angle designed with virtual 62.5° cap angle and gives its simulation results.

Delay-Derived CBT Circular Flat-Panel Array, 40° Coverage Angle, 62.5° cap angle
Expanded Source Configuration

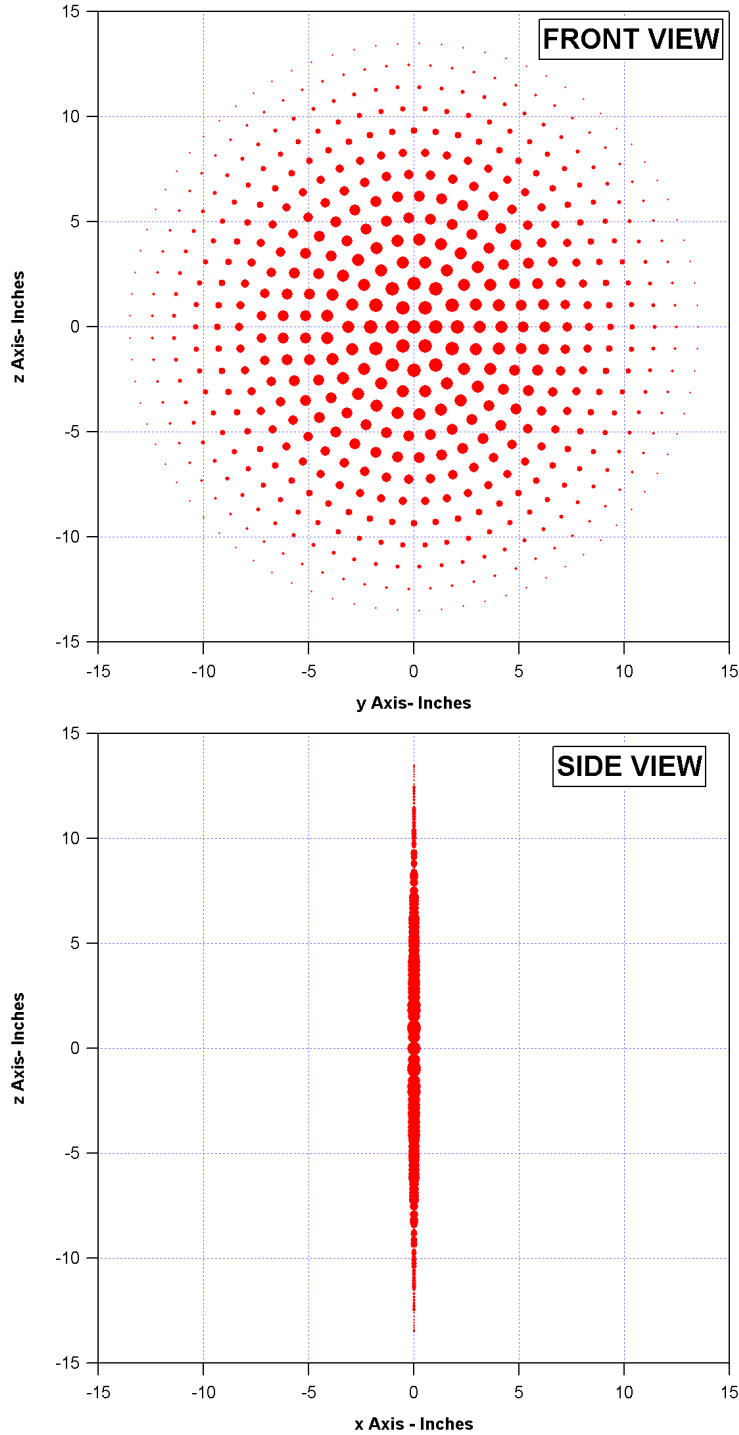

Fig. 20. Expanded front and side views of the 27 inch (0.69 m) diameter (two wavelengths at 1 kHz) of the delay-derived circular flat-panel CBT array designed for 40° coverage with a 62.5° cap (arc) angle. This array has 556 sources arranged in 13 radial rings with a single center source. Each ring was Legendre shaded and delayed with values given previously in Table 1. Compare this array with the conventional spherical-cap array in the previous appendix.

Source Configuration and Beamwidth

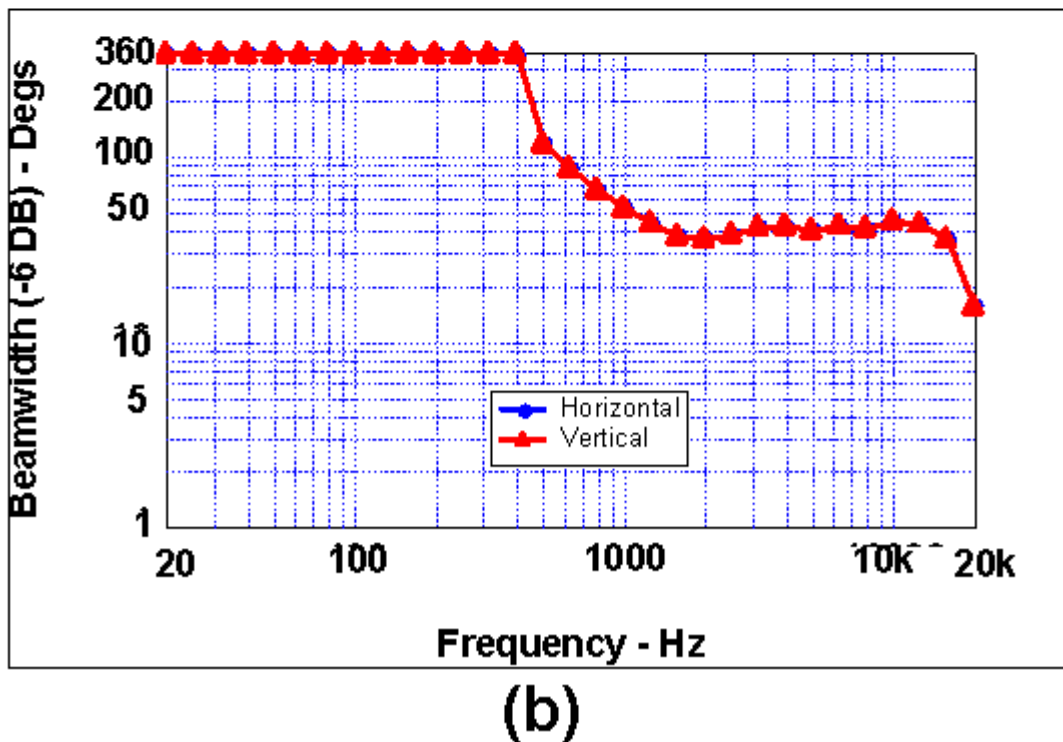
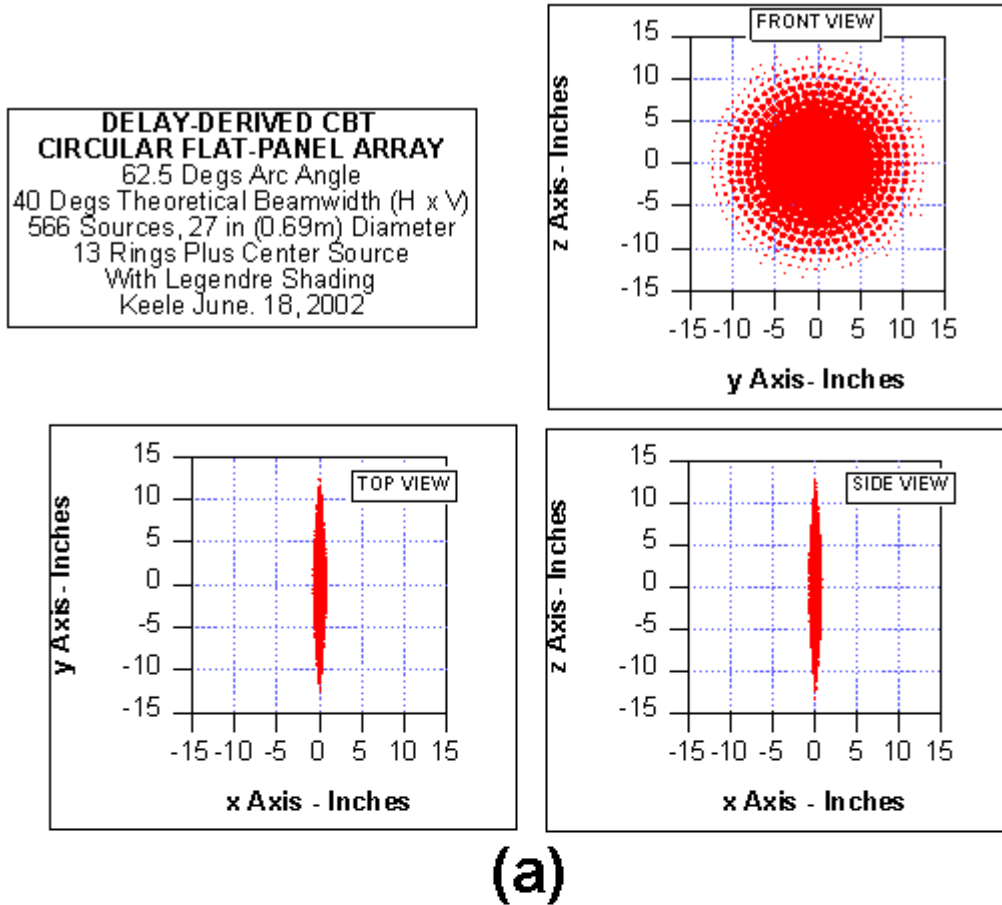
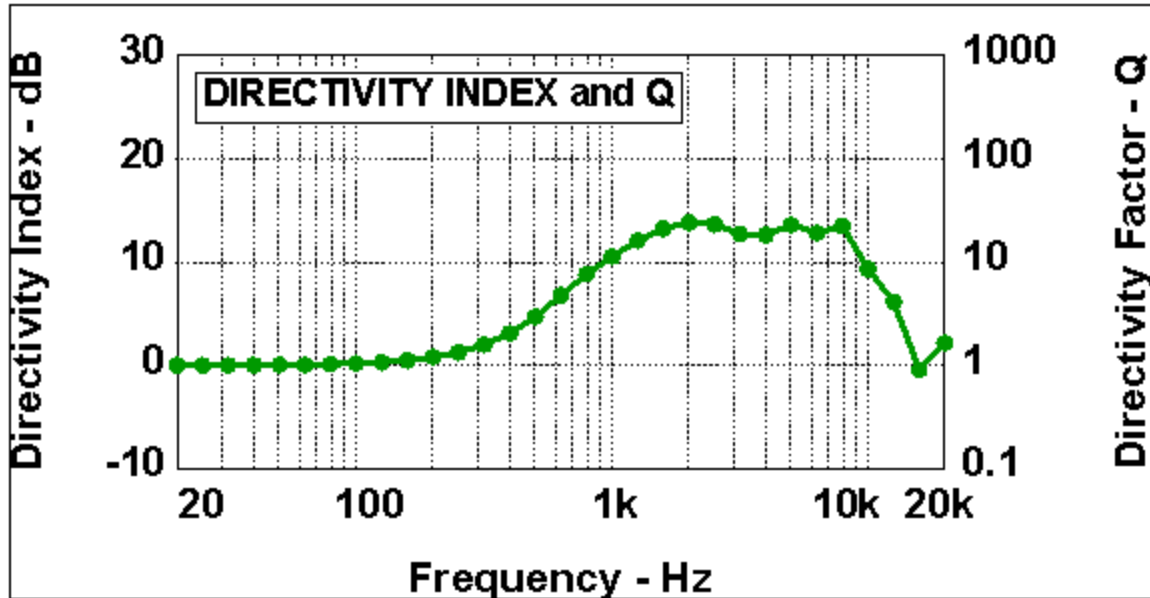
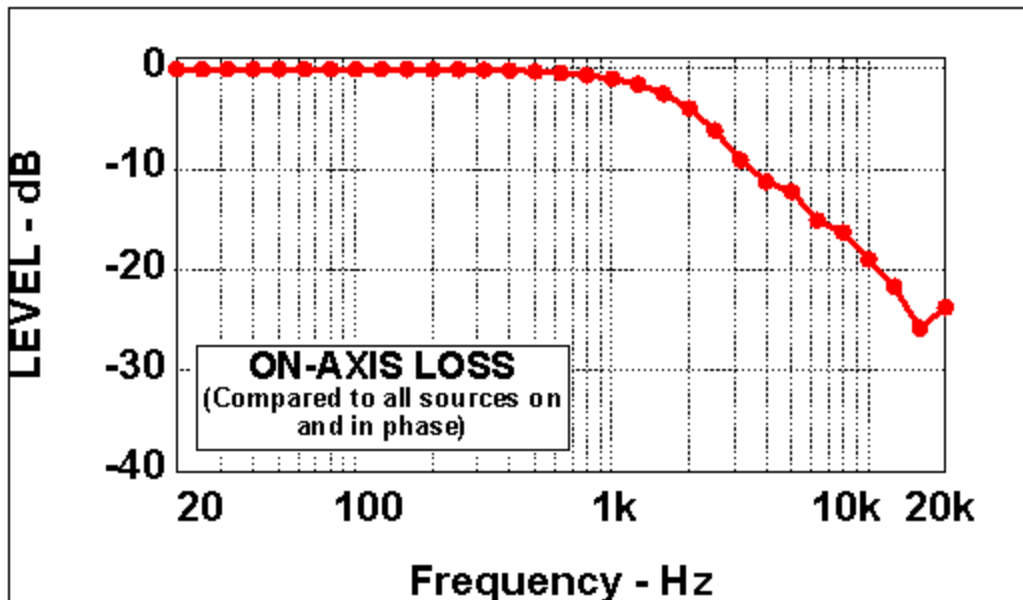

Fig. 21. (a) Source configuration and (b) beamwidth vs. frequency of the delay-derived circular flat-panel CBT array designed for 40° coverage with a 62.5° cap (arc) angle of Fig. 20. Compare with the conventional CBT array data of Fig. 15.

Directivity and On-Axis Response



(c)



(d)

Fig. 22. (c) Directivity index and Q, and (d) on-axis frequency response (loss) of the delay-derived circular flat-panel CBT array designed for 40° coverage with a virtual 62.5° cap (arc) angle of Fig. 20. Compare with the conventional CBT array data of Fig. 16.

Horizontal Polars (Normalized to on axis)

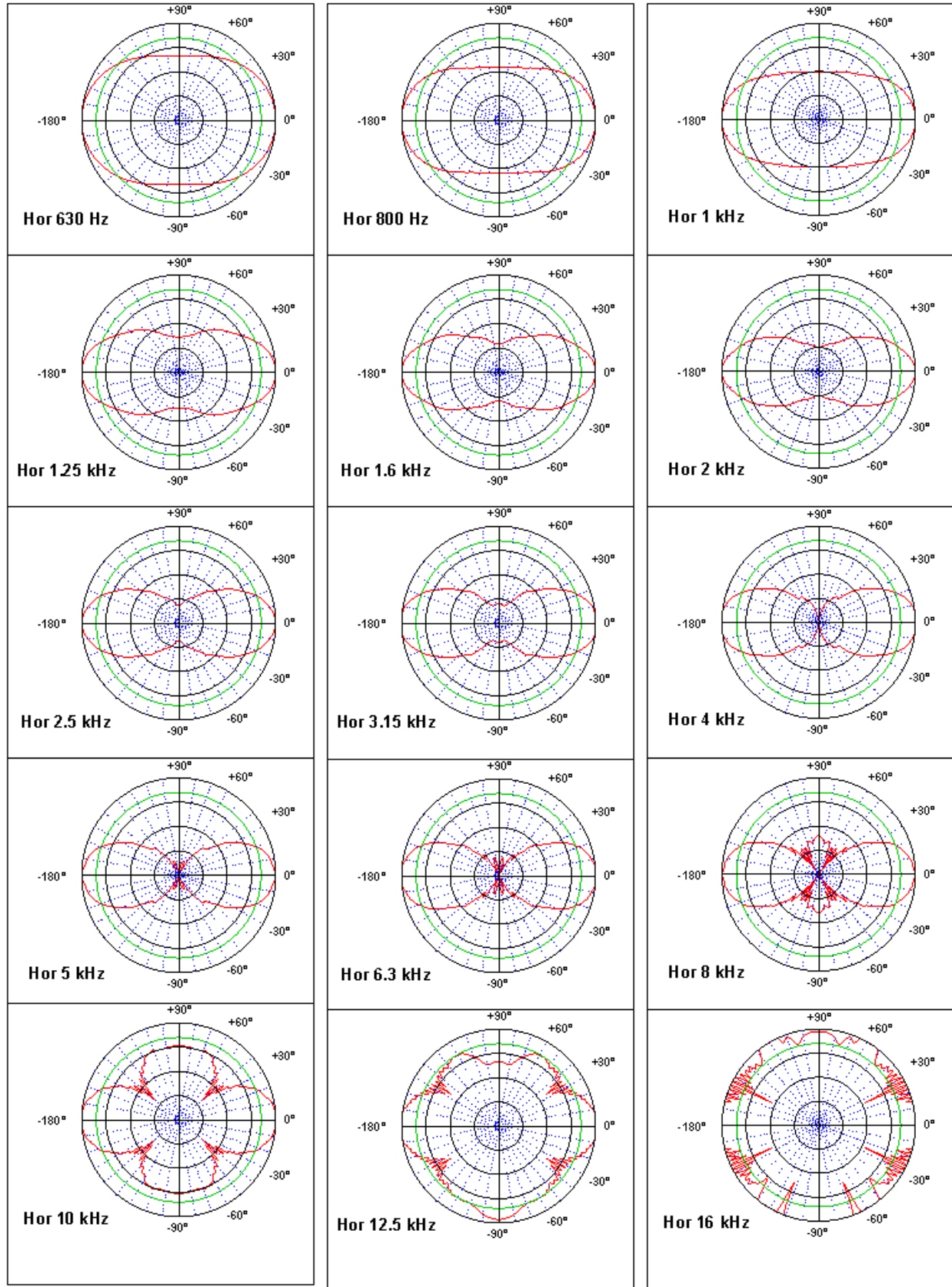

Fig. 23. Horizontal polars (normalized to the on-axis level) of the of the delay-derived circular flat-panel CBT array designed for 40° coverage with a virtual 62.5° cap (arc) angle of Fig. 20. Compare with the conventional CBT array data of Fig. 17.

Vertical Polars (Normalized to on axis)

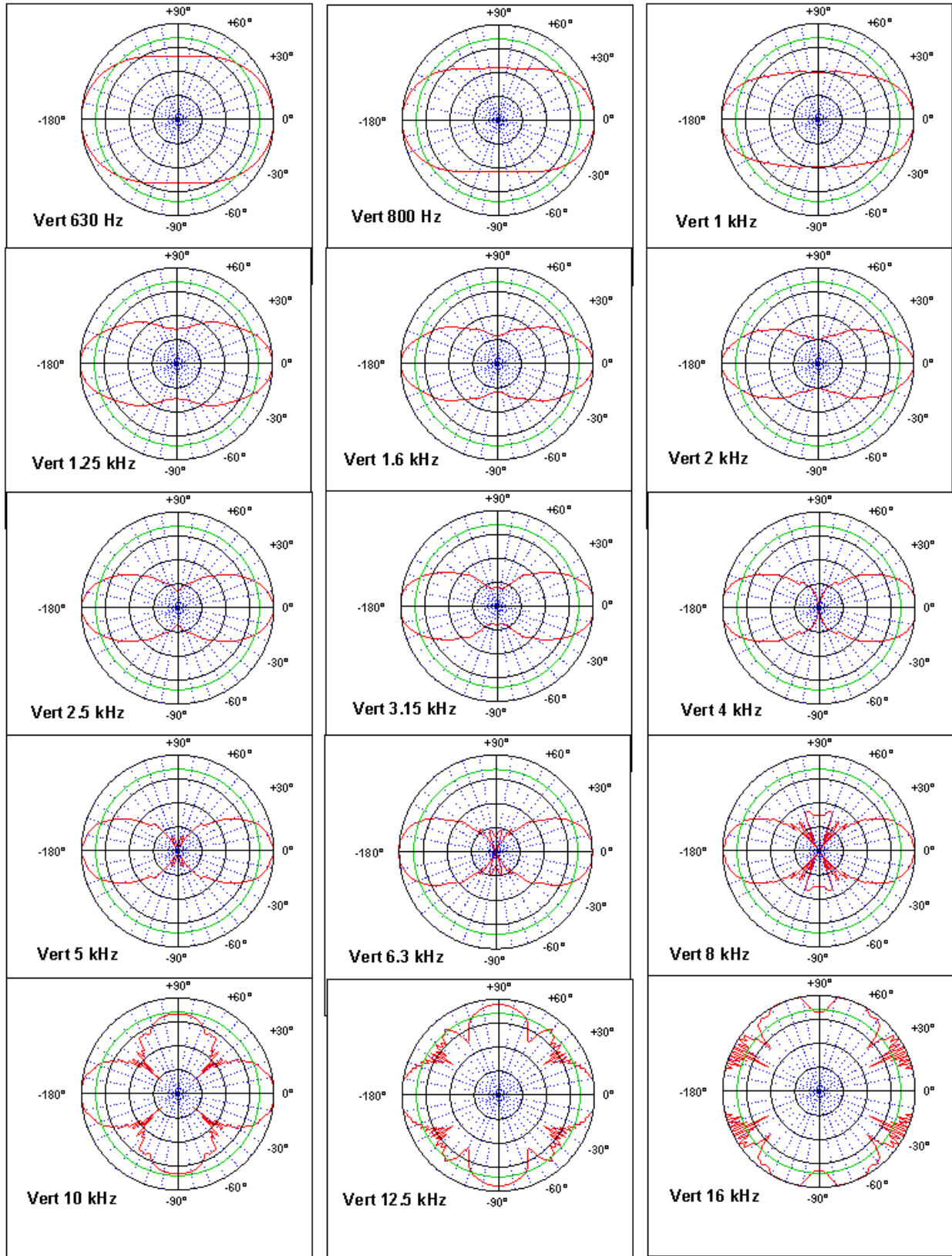

Fig. 24. Vertical polars (normalized to the on-axis level) of the of the delay-derived circular flat-panel CBT array designed for 40° coverage with a virtual 62.5° cap (arc) angle of Fig. 20. Compare with the conventional CBT array data of Fig. 18.

On-Axis Foot Prints

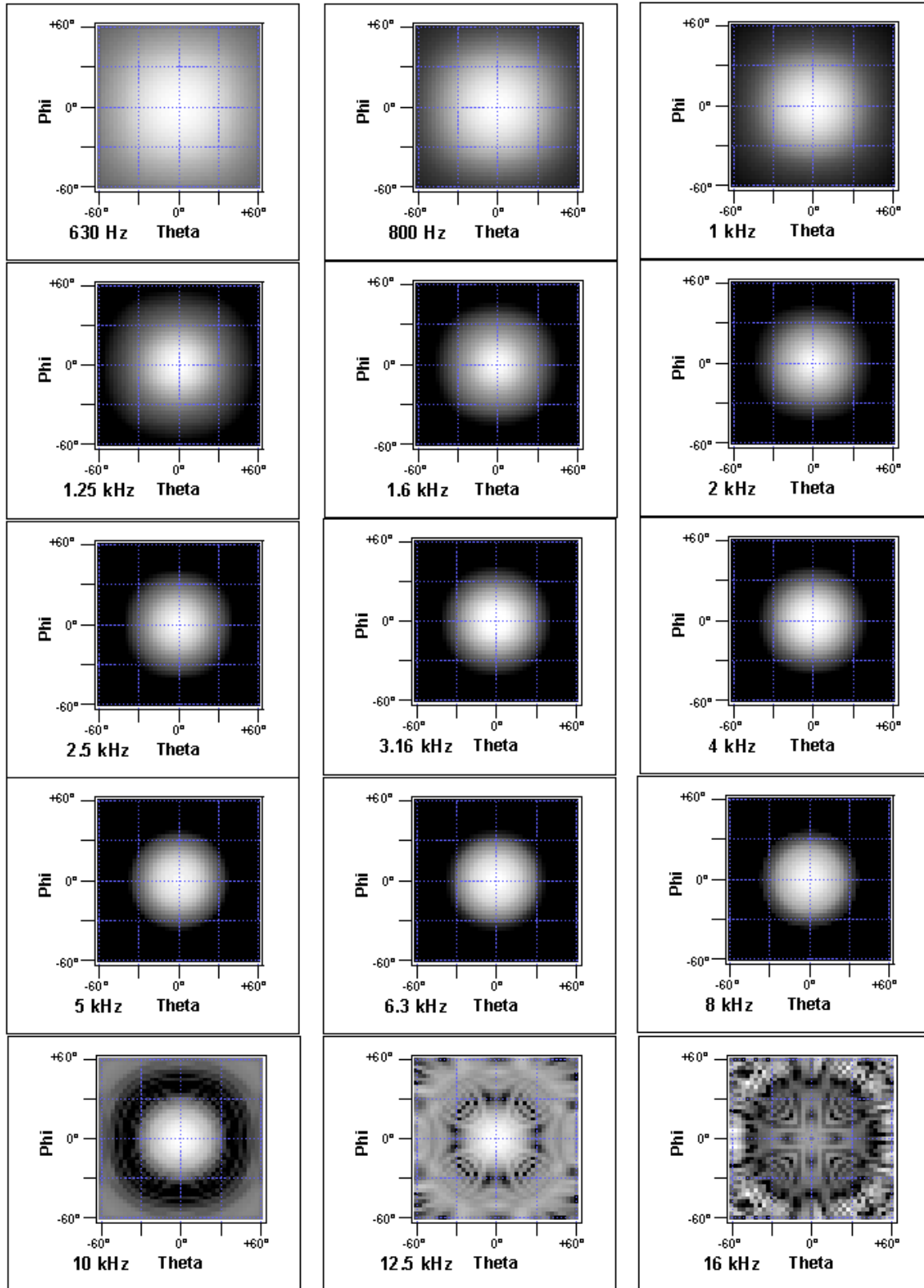

Fig. 25. On-axis footprints of the of the delay-derived circular flat-panel CBT array designed for 40° coverage with a virtual 62.5° cap (arc) angle of Fig. 20. Compare with the conventional CBT array data of Fig. 19.